

INTERNATIONAL ENERGY AGENCY
energy conservation in buildings and
community systems programme

Technical Note AIVC **42**

**Current Ventilation and Air Conditioning
Systems and Strategies**

February 1994



Air Infiltration and Ventilation Centre

University of Warwick Science Park

Sovereign Court

Sir William Lyons Road

Coventry CV4 7EZ

Great Britain

This report is part of the work of the IEA Energy Conservation in Buildings & Community Systems Programme.

Publication prepared by

Annex V Air Infiltration and Ventilation Centre

Document AIC-TN-42-1994

ISBN 0 946075 72 7

Participating countries:

Annex V

Belgium, Canada, Denmark, Germany, Finland, France,
Italy, Netherlands, New Zealand, Norway, Sweden,
Switzerland, United Kingdom, and United States of
America

Distribution: Annex V only

Additional copies of this report may be obtained from:

The Air Infiltration and Ventilation Centre
University of Warwick Science Park
Sovereign Court
Sir William Lyons Road
Coventry CV4 7EZ
Great Britain

Current Ventilation and Air Conditioning Systems and Strategies

Mark J Limb

©Copyright Oscar Faber plc 1994

All property rights, including copyright are vested in the Operating Agent (Oscar Faber Consulting Engineers) on behalf of the International Energy Agency.

In particular, no part of this publication may be reproduced, stored in a retrieval system or transmitted in any form or by any means, electronic, mechanical, photocopying, recording or otherwise, without the prior written permission of the Operating Agent.

Preface

International Energy Agency

The International Energy Agency (IEA) was established in 1974 within the framework of the Organisation for Economic Co-operation and Development (OECD) to implement an International Energy Programme. A basic aim of the IEA is to foster co-operation among the twenty-one IEA Participating Countries to increase energy security through energy conservation, development of alternative energy sources and energy research development and demonstration (RD&D). This is achieved in part through a programme of collaborative RD&D consisting of forty-two Implementing Agreements, containing a total of over eighty separate energy RD&D projects. This publication forms one element of this programme.

Energy Conservation in Buildings and Community Systems

The IEA sponsors research and development in a number of areas related to energy. In one of these areas, energy conservation in buildings, the IEA is sponsoring various exercises to predict more accurately the energy use of buildings, including comparison of existing computer programs, building monitoring, comparison of calculation methods, as well as air quality and studies of occupancy. Seventeen countries have elected to participate in this area and have designated contracting parties to the Implementing Agreement covering collaborative research in this area. The designation by governments of a number of private organisations, as well as universities and government laboratories, as contracting parties, has provided a broader range of expertise to tackle the projects in the different technology areas than would have been the case if participation was restricted to governments. The importance of associating industry with government sponsored energy research and development is recognized in the IEA, and every effort is made to encourage this trend.

The Executive Committee

Overall control of the programme is maintained by an Executive Committee, which not only monitors existing projects but identifies new areas where collaborative effort may be beneficial. The Executive Committee ensures that all projects fit into a pre-determined strategy, without unnecessary overlap or duplication but with effective liaison and communication. The Executive Committee has initiated the following projects to date (completed projects are identified by *):

- I Load Energy Determination of Buildings*
- II Ekistics and Advanced Community Energy Systems*
- III Energy Conservation in Residential Buildings*
- IV Glasgow Commercial Building Monitoring*
- V Air Infiltration and Ventilation Centre
- VI Energy Systems and Design of Communities*
- VII Local Government Energy Planning*
- VIII Inhabitant Behaviour with Regard to Ventilation*
- IX Minimum Ventilation Rates*

- X Building HVAC Systems Simulation*
- XI Energy Auditing*
- XII Windows and Fenestration*
- XIII Energy Management in Hospitals*
- XIV Condensation*
- XV Energy Efficiency in Schools*
- XVI BEMS - 1: Energy Management Procedures*
- XVII BEMS - 2: Evaluation and Emulation Techniques
- XVIII Demand Controlled Ventilating Systems*
- XIX Low Slope Roof Systems
- XX Air Flow Patterns within Buildings*
- XXI Thermal Modelling*
- XXII Energy Efficient Communities
- XXIII Multizone Air Flow Modelling (COMIS)
- XXIV Heat Air and Moisture Transfer in Envelopes
- XXV Real Time HEVAC Simulation
- XXVI Energy Efficient Ventilation of Large Enclosures
- XXVII Evaluation and Demonstration of Domestic Ventilation Systems
- XXVIII Low Energy Cooling Systems

Annex V Air Infiltration and Ventilation Centre

The IEA Executive Committee (Building and Community Systems) has highlighted areas where the level of knowledge is unsatisfactory and there was unanimous agreement that infiltration was the area about which least was known. An infiltration group was formed drawing experts from most progressive countries, their long term aim to encourage joint international research and increase the world pool of knowledge on infiltration and ventilation. Much valuable but sporadic and uncoordinated research was already taking place and after some initial groundwork the experts group recommended to their executive the formation of an Air Infiltration and Ventilation Centre. This recommendation was accepted and proposals for its establishment were invited internationally.

The aims of the Centre are the standardisation of techniques, the validation of models, the catalogue and transfer of information, and the encouragement of research. It is intended to be a review body for current world research, to ensure full dissemination of this research and based on a knowledge of work already done to give direction and firm basis for future research in the Participating Countries.

The Participants in this task are Belgium, Canada, Denmark, Germany, Finland, France, Italy, Netherlands, New Zealand, Norway, Sweden, Switzerland, United Kingdom and the United States of America.

Forward and Scope

The goal of this report is to promote a wider understanding into the choices of ventilation systems and strategies. It is aimed at building professionals, designers, architects, researchers and the clients. Its purpose is to generate a deeper understanding into why particular systems and strategies are chosen, and how best to provide the required ventilation or full air conditioning. The classification of systems throughout this report should assist the reader in understanding the role of each system in achieving the stated goals.

Acknowledgements

The preparation of this report depended on the effort and cooperation of many individuals and organisations. In particular David Harrje a consultant from the United States, who provided valuable advice and assistance on the content and structure of this report. The author would also like to thank Bas Knoll from TNO in the Netherlands and all members of the AIVC Steering group for their input and advice.

Grateful acknowledgement is also made to IEA Annex 11 - Energy Auditing and to Future Systems, the CIBSE Journal and Ove Arup and Partners for the use of illustrations.

Contents

1. Introduction	1
1.1 Aim	1
2. Changes in Ventilation Provisions Since the 1970's	2
3. Natural Ventilation Versus Mechanical Ventilation	3
3.1 Natural Ventilation Strategies	3
3.2 Mechanical Ventilation Strategies	5
4. The Choice of Ventilation Strategy for Dwellings	7
5. The Choice of Ventilation Strategy for Commercial Developments	10
6. Classification of Dwelling and Commercial Ventilation Strategies and Systems	14
7. Factors to Consider When Selecting a Ventilation Strategy	17
8. Conclusions	22
9. References	25
Appendix A Classification Review.	29
A.1 ASHRAE Classification of Air Conditioning Systems.	30
A.2 CIBSE Classification of Air Conditioning Systems.	34
A.3 CARRIER Classification of Air Conditioning Systems.	41
A.4 Knoll's Classification of Ventilation Systems.	51
Appendix B - Ventilation Systems and Strategies Survey Form.	55
Appendix C - Ventilation System and Strategy Survey Results.	59
C2- Ventilation System Strategies Survey Replies	62

1. Introduction

Increased awareness of the need to conserve energy and at the same time to maintain the quality of the indoor air and occupant comfort has led to greater control over the ventilation process. Such control requires improved specification of ventilation rates, improved tightness of structures so that flow paths are better defined, and improved ventilation systems, whether natural or mechanical. Since the Energy Crises there have been a number of developments resulting in changes to the way ventilation is provided and at what levels it is required. Some of these criteria have already been examined, Trepte and Haberda (1989) studied the criteria for the specification of ventilation rates and Elmroth and Levin (1983) have surveyed the methods by which different countries have attempted to improve air tightness. What has been lacking, until recently, was a review of the role of ventilation systems themselves.

Knoll (1991) did provide such a ventilation systems review but restricted his study to room air movement systems, most of which assume an airtight room or building in which to operate. A similar classification system issued by SCANVAC also restricted their review to room air distribution systems (SCANVAC, 1991). These guidelines classify indoor climate in terms of percentage persons dissatisfied, no value of ventilation is given. Ventilation is determined to achieve three levels of perceived air quality in accordance with the European Collaborative Action document "Indoor Air Quality and Its Impact on Man". The ideal situation of sealed rooms and mechanical supply and extract systems allows ventilation air to be provided in the correct quantities at the right locations for the particular applications, while keeping energy efficiency foremost. However, traditionally ventilation has been provided by natural means, through windows and adventitious openings within the building envelope. These strategies can give poor control and are often unreliable. Many changes have occurred during the past twenty years and by examining how these traditional ventilation strategies have changed and what has been the main influencing factors it is possible to classify ventilation systems and strategies in terms of their reliability and the level of control.

1.1 The Aim

The aim of this study is to examine common ventilation and air conditioning systems and strategies for both domestic and commercial buildings in the member countries of the AIVC.

To help identify common systems, a literature search was conducted and the system descriptions of two professional institutions and one commercial supplier were examined. This led to the establishment of a common classification of ventilation and air conditioning systems.

It was found that much information exists regarding ventilation in dwellings, but little corresponding data can be found for commercial office buildings. Using the newly developed classification defined in section 6, a survey was conducted to establish the nature of ventilation systems currently being specified for commercial buildings throughout the AIVC member countries. The results of this survey are outlined and discussed in Appendix C.

Once identified: natural, mechanical and air conditioning systems have been compared based upon a number of criteria, including climate, the level of occupant interaction and level of system control. This evaluation of systems is not designed to be exhaustive, but to act as a platform for further discussion.

2. Changes in Ventilation Provisions Since the 1970's

During the 1970s two economic disruptions occurred, both causing sharp increases in the price of demanded fuels, mainly oil. The most significant of these was the "energy crisis" of 1973 which brought a quick end to the low energy prices previously enjoyed. The second oil crisis occurred in 1979/80 but its effect, although less dramatic, proved that such crises could be repeated at any time.

Research and actions since the oil crises have demonstrated that much space heating and cooling energy was being wasted by excessive levels of infiltration. For example, the development of automated air infiltration equipment documented the levels of energy loss (Harrje and Hunt, 1975). Committees and research programs were established to investigate and report upon the significance and reducibility of high infiltration losses. Examples of such initiatives include the "Tightness Group" set up in 1977 by the Swedish Council for Building Research (Kronvall, 1990), and the German research program "Ventilation and Air Infiltration in Residential Buildings" (Trepte, 1985). Both of these initiatives focused directly on infiltration losses. The Canadian Home Insulation Program (CHIP) and the Canadian Oil Substitution Program (COSP) set up in 1979 in Canada dealt with component leakage performances (Riley, 1990). Two projects run in the UK and USA during the early 1980's demonstrated that air infiltration related energy loss was a significant factor in commercial buildings (IEA Annex 4, Glasgow Commercial building, and eight US Government Service Buildings, Grot and Persily, 1983).

Many investigations concentrated on the domestic building sector, representing over 50% of the total building energy demand in Europe in 1977 (IEA 1986). Their main objectives were to identify technical solutions to reduce infiltration losses and then incorporate them into energy conservation legislation. These investigations demonstrated the importance of infiltration losses and it soon became clear that the amount of energy lost in this way was significant, but nevertheless reducible (Sherman, 1984) (Elmroth and Levin 1983) (AIVC 1981).

Although the energy crises called for reductions in both infiltration and natural ventilation, these methods are still used providing needed ventilation in many countries, especially those with mild or temperate climates. In light of research into the energy implications of ventilating by natural means, natural ventilation has become more controlled and better designed, while the heat losses associated with infiltration have been reduced by conservation measures. These included improvements in insulation and airtightness levels of many building envelopes. Improvements have been achieved by changes in legislation (codes and standards) and by educating the general public to demand more energy efficient products.

In more severe climates mechanical ventilation systems have become the norm. Conservation measures have led to very tight building envelopes. To maintain good levels of indoor air quality these have been coupled with mechanical ventilation systems. The different systems and their applications are discussed in the next section.

3. Natural Ventilation Versus Mechanical Ventilation

This section seeks to examine different natural and mechanical ventilation systems and strategies currently found in dwellings and commercial buildings throughout the member countries of the Air Infiltration and Ventilation Centre.

Three main strategies can be identified,

(i) Natural ventilation - the provision of outdoor air into a space through openings within the building fabric, driven by the natural forces of wind and temperature.

(ii) Mechanical ventilation - the provision of outdoor air or extraction of room air by the use of one or more fans.

(iii) Space conditioning - the artificial process of treating the air to adjust its temperature, humidity, cleanliness, air quality circulation and distribution by the use of mechanical ventilation (e.g. air conditioning or the use of HVAC systems).

These strategies are further examined below.

3.1 Natural Ventilation Strategies

The primary division when discussing ventilation systems is between natural and mechanical ventilation. Several natural ventilation strategies can be identified:

- 1) Infiltration.
- 2) Ventilation through Windows.
- 3) Ventilation through Purpose-Provided Openings.
- 4) Passive Stack Ventilation - via Purpose-Provided Openings and Vertical Stacks.

Before the 1970s the high levels of infiltration experienced in buildings were not frequently recognised as a problem. During the economic boom periods of the 1950s and 60s energy was cheap and reducing consumption was not always a priority. Natural ventilation strategies were cheap, simple to install and operate, and allowed direct occupant access. The main criticism of these strategies surrounds its inherent uncontrollability and unreliability, both of which stem from its two driving forces; stack effect (temperature differences) and wind pressures. These strategies were therefore unsuitable for applications requiring constant air flow rates, being more appropriate in narrow buildings with limited internal partitioning that offered low resistances to air flow. Air quality control is limited because the addition of filters is impossible. Temperature control is also poor, with temperature differences between ventilation air and room air as high as 30 degrees Celsius or higher, therefore even a limited flow can cause an extreme thermal load, either positive or negative. The result is draughts and comfort problems from poorly mixed internal air. However, it is possible to pre-heat incoming air at purpose-provided opening vents, but few designs, currently treat air in this way. Heat recovery is impossible with natural ventilation systems (Bekker J, 1991).

Infiltration through cracks and gaps in the building envelope must also be considered as part of the ventilation process since it occurs in all buildings to varying degrees. Infiltration represents the least controllable and unreliable of the natural ventilation options. More control

is obtained by reducing infiltration and providing windows or purpose-provided openings within the building envelope, such as vents, etc. which can be controlled by the occupants. In some countries passive stack ventilation has become more widely used, where the stack effect and wind pressures have been utilized to drive a natural exhaust system. Such systems are designed to remove pollutants (including considerable moisture) from kitchens, bathrooms and toilets. The air inlet is via purpose-provided openings within the building fabric (Uglow, 1989).

The introduction of a variety of technical improvements such as the installation of trickle vents (O'Sullivan and Jones, 1982) self regulated air inlets (Riberon and Millet 1992) and humidity controlled ventilation systems, such as AERECO (Jardinier and Simonnot, 1990), have been attempted to improve the level of control offered by these ventilation systems. Low pressure controlled natural air inlets have also recently been introduced (Knoll 1991).

More recently environmental issues such as reductions in Chlorofluorcarbon (CFC) emissions in line with the Montreal Protocol (Butler, 1989) have resulted in many so called new "Green" designs which incorporate natural ventilation strategies. Many of these designs challenge pre-conceived aesthetics as well as current methods of providing occupant ventilation. Figure 3.1 shows an example of such a design.

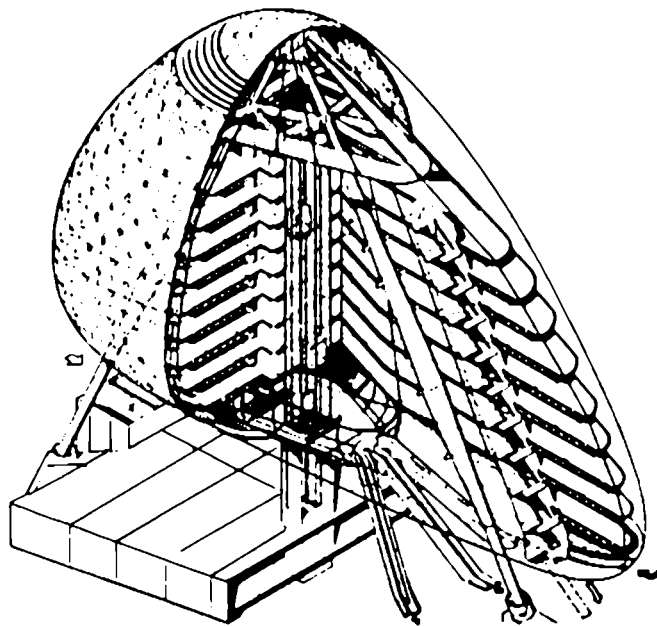

Figure 3.1 A Green Office Building design by the Future Systems: project 166. Reproduced with kind permission from Future Systems, the CIBSE Journal and Ove Arup and Partners

There are, however practical limits to the extent to which air flows of these systems can be influenced since they rely of the inherent uncontrollability and unreliability of nature. Where further control is shown to be needed, the route must be towards good airtight design (to limit infiltration) and the introduction of mechanical ventilation.

Such well designed air distribution systems increase the possibilities for more effective building use, which is especially important with the present (high) level of specifications for

indoor climate and the use of buildings (for example, high occupant and machine densities and reduced building heights). However, in order to achieve a really satisfying indoor climate with good indoor air quality there needs to be a proper balance between the building, its use (including occupant patterns) and its ventilation system.

3.2 Mechanical Ventilation Strategies

The desirability for more controllable air flows within buildings has led to the introduction of mechanical ventilation systems. Three generic forms of mechanical ventilation exist, these being:

- 1) Mechanical Extract - Natural Supply.
- 2) Mechanical Supply - Natural Extract.
- 3) Balanced - Mechanical Supply and Extract.

In mechanical extract/natural supply systems, fans mounted in the external envelope remove indoor air, while supply occurs through infiltration paths, windows and purpose-provided openings. Natural passive stack systems can be converted into mechanical extract systems by the introduction of a fan into the vertical airways. These systems remove polluted air from the point of generation resulting in depressurisation of the building, which leads to higher levels of infiltration. Their use has been discouraged in buildings with open combustion appliances since they can induce back flow of combustion gases through flues (Lstiburek, 1991). Attempts to govern the supply air have included greater envelope tightness and the introduction of purpose-provided openings. Mechanical extract systems may be combined with a heat pump which can be used to remove the heat from the exhaust air stream and transfer it to domestic hot water or central heating system. For example Bjornevad and Post (1990) discuss developments of such systems for direct electrically heated houses in Sweden.

Mechanical supply/natural extract systems are the reverse of mechanical extract systems, the creation of a positive pressure indoors forces air to be exhausted through cracks or other openings in the building fabric. Supply systems are not normally suitable for dwellings, because moisture can be forced into the fabric, which in certain circumstances can lead to interstitial condensation. Supply systems are dilution systems and can not be used to remove specific pollutants, such as combustion by-products. Such systems pressurise a building, causing the exfiltration of indoor air. This can be useful where the outdoor air is of poor quality and needs to be cleaned by filtration before distribution to the occupied space. Building pressurisation prevents the ingress of contaminated air. An implied disadvantage of supply systems is that heat recovery is not possible, since the exhaust air will leave from many locations.

The only configuration that will ensure air is supplied at the correct place and at the required rate are full mechanical systems. Balanced systems both mechanically supply and extract ventilation air. These systems allow the addition of filters, pre-heaters, heat recovery devices and other air cleaning equipment. Balanced systems may only operate successfully in conjunction with very tight building envelopes, that provide good control over the supply and exhaust of ventilation air. In countries that experience severe winter temperatures, balanced systems are often connected to pre-heaters (to heat incoming supply air at the point of delivery, for example air is delivered through vents behind radiators) and heat recovery devices (to maximize energy savings) are also incorporated. In moderate climates or in

buildings with good insulation pre-heating can supply the total heating, so the heating system is replaced. Balanced systems which are slightly over pressurised are common in commercial buildings where a positive pressure ensures that only filtered, conditioned air enters a space. It is also interesting to note that in less air tight buildings unbalanced mechanical supply and extract may also be used, although at lower efficiencies than balanced systems incorporating heat recovery.

Mechanical installations are expensive (a major component of the cost of the project) and the life cycle of these technical installations are normally much shorter (15 to 20 years) than the life cycle of the building. Such systems necessitate an increase in building volume for the inclusion of duct systems and equipment which will also increase the total cost of the project. Regular maintenance costs also have an important impact on the cost viability of these systems.

An important consideration for any mechanical system is the indoor air flow that results, the indoor air quality and the draught risk. These topics have been discussed by IEA Annex 20, Air Flow Patterns within Buildings (Chen et.al., 1992).

A recent development in some cases has been a move away from traditional mixing systems to displacement ventilation systems. The principle of these systems is that cool air is supplied with a low momentum through large inlet devices near the floor. The cool air is heated by heat sources in the room, and convective plumes are formed above the heat sources. Often contaminants released from the heat sources are entrained in the convective plumes. The ventilation air is both a source of momentum and buoyancy. The convective up currents have to be balanced with the supply of ventilation air and high level extract, otherwise a layer of heated and contaminated air begins to descend from the ceiling. These systems are common in Scandinavia especially in industrial buildings (Breum and Skotte, 1992; Guntermann, 1992)

A further development is the use of evaporative cooling systems which are compatible with mechanical ventilation systems. These systems are being dealt with in more detail by IEA Annex 28 Low Energy Cooling Systems.

4. The Choice of Ventilation Strategy for Dwellings.

The question now arises that if the ventilation process can be precisely controlled by mechanical systems, why are natural ventilation systems and strategies still used in some countries? Limb (1992) has examined the occurrence of different systems in different countries and suggested that the level of system complexity is governed by economic factors (the availability and cost of primary fuel and energy, the level of industrialisation and the significance of infiltration heat losses, etc.). These factors in turn depend largely upon climate.

In countries that experience severe winter temperatures the difference between the indoor design and outdoor ambient temperature can be large, such countries include Sweden, Finland, Norway, Canada, regions of the USA and Switzerland, and can be classified as Boreal or Polar. The importance of reducing infiltration heat loss in these regions was more urgent because of their lack of available energy resources, their harsh terrain and severe climate. These factors resulted in a reliance on imported fuel which was worsened by high winter space heating demands. Reducing fuel consumption would lessen their dependence upon foreign fuel markets and help in the creation of a more competitive economy, and improved standard of living for residents.

Countries classified as having a temperate climate, such as much of Europe and North America, also conducted similar research to reduce winter space heating demands and infiltration heat losses. However, the potential to save energy in these countries was reduced because of lower indoor and outdoor temperature differences, more acceptable terrain and the greater abundance of available energy resources. Attempts to save energy and reduce infiltration were therefore less intensely pursued.

It is also apparent that ventilation is essential for occupant health and comfort. As the drive for energy efficiency increased, the indoor air quality in many buildings was reduced. In contrast, the specification of ventilation rates to ensure that occupants receive adequate quantities of fresh air has helped maintain indoor air quality. However, many of these standards only specify ventilation rates for basic needs. With the introduction of new building materials, practices and technology it has become clear that the basis behind many of these standards may no longer adequate to achieve good indoor air quality.

The UK COSHH Regulations (Youle, 1991) give a wide range of available options to control occupant exposure to pollutants. The most important is that such pollutants should be avoided. Substitution using less emitting substances is the next best option. Only when these two procedures are impractical should extract ventilation be employed at the pollutant source. Finally, the most common but least effective cure is dilution. A recent development has been to specify ventilation for the removal of a specific pollutant, such as tobacco smoke or moisture. Standards such as these have implications with regards to the ventilation strategy adopted, for example, passive stack, mechanical extract or balanced systems are the only systems that are designed to remove a specific pollutant from a specific location, whereas natural ventilation or mechanical supply provide ventilation for basic needs but will only dilute indoor pollutants.

As the envelopes of dwellings become more air tight, the more important ventilation has become to ensure that the quality of the indoor air is maintained at a high level and free from harmful contaminants. The severity of the climate determines the potential for energy savings

via conservation strategies. In places where the energy saving potential is least, natural ventilation strategies or hybrid mechanical and natural strategies have been adopted. Where large energy savings can be made, very tight building envelopes combined with balanced mechanical ventilation systems and heat recovery devices are common.

These trends appear strongest in the case of dwellings. Many research projects have focused on this sector, principally because it represents the single largest consumer of energy. Additionally, commercial buildings often present further difficulties such as the need to treat excessive heat gains within the ventilation strategy.

In many temperate regions, dwellings were traditionally ventilated by natural means by virtue of wind and temperature effects through openable windows and doors and by infiltration through cracks in the building fabric. Such ventilation for basic needs is common in Belgium (Wouters, 1988), Germany (Schmickler, 1988), Netherlands (Gids de, 1984), the United Kingdom (Etheridge, 1982), and the United States of America (Hekmat, 1986). Although many older buildings are still ventilated in this manner improved airtightness and more controlled natural ventilation systems are currently being adopted. To provide additional ventilation, mechanically operated local intermittent fans have become common in all countries, they are installed as wall mounted extract fans or as fans above kitchen ranges. For example in the United Kingdom, mechanical extract fans giving an extract flow rate not less than 60 l/s (or 30 l/s if in an extracting cooker hood) to be operated intermittently. In addition the kitchen would have a trickle ventilator. Similar requirements for other countries are reviewed in Limb (1993).

Where the climate is more severe, improved airtightness has meant that natural ventilation through windows and doors cannot be relied upon to secure adequate ventilation. In these buildings, passive systems driven by the stack effect and enhanced by operating combustion appliances are common. The supply of ventilation air is through purpose-provided openings in the building envelope. Such systems are common in Canada (Hamlin, 1990), Finland (Railio, 1984), France (Bienfait, 1990) and Switzerland (Hartmann, 1989).

In modern buildings incorporating duct systems, they are now used to remove moist room air from bathrooms, WC's and kitchens. In Scandinavia and the Netherlands, passive stack systems have been used in both single family and multi-story dwellings, Finland (Railio, 1984), Netherlands (Knoll, 1992) Norway (Brunsell, 1989) and Sweden (Kronvall, 1989).

Another route towards the introduction of mechanical ventilation has been the installation of fans inside vertical ventilation ducts, cooker hoods and window fans. Mechanical extract systems are now common in France (Bienfait, 1990), Canada, Finland, and the Netherlands. For example 84% of newly built French dwellings are equipped with mechanical exhaust systems (Riberon et al 1993), 90% of all new Canadian houses incorporate these systems (Kadulski, 1990), and in 1988, 60% of flats in Finland were equipped with mechanical exhaust systems (Kohonen, 1990). In the Netherlands, mechanical exhaust systems are required in buildings over 13 metres high.

The installation of mechanically balanced, supply and extract systems in very tight buildings increases the potential for greater energy savings. These systems further reduce the effects of infiltration which however, still occurs. Nearly all new houses and other buildings in Sweden are equipped with full mechanical ventilation systems with heat recovery devices (air-to-air

heat exchangers or air-to-air/water heat pumps) (Kronvall J, 1990). These systems are also common in Norway (Brunsell and Skaret, 1989) Finland (Railio J, 1984) and Canada (Robinson T, 1990).

In the United States a typical new home combines ventilation with heating and cooling needs. A typical new home in the United States uses a ducted heating system. In the past these were warm air gas fired furnaces (it could also be oil fired but these were less popular). However, in many areas of the United States a cooling coil is installed in the ducting where it leaves the furnace. Outside is the other half of the unit, the compressor and heat rejection coil. This addition for an average home costs less than \$2000. Another choice is the electric heat pump which can provide more than two times the heating per kilowatt of electricity during the heating season. In the cooling season a reversing valve allows the heat pump to function as an air conditioner. Even with water based heating systems, much of the US adds through the window or wall air conditioning units to cool part or all of the house. Vents in these air systems introduce ventilation air to the house.

It can be seen from the above examples that the choice of ventilation strategy and air flow systems for dwellings are often clearly linked to climate. However, if one examines commercial buildings this assumption is not so apparent.

5. The Choice of Ventilation Strategy for Commercial Developments

The specification of commercial systems and strategies depend on different criteria with natural ventilation being a possible choice in small buildings. However, in large multi-story complexes, mechanical ventilation or very often air conditioning may be necessary.

In commercial developments, the aim of ventilation is not only to provide for basic ventilation needs and to control the level of pollutants but also to manage any thermal loads, generated by high equipment and occupancy densities. Thus thermal load control by shading, careful determination of the internal load schedules and appropriate building masses are also to be considered. Where adequate natural ventilation cannot be provided mechanical ventilation is therefore necessary. Examples include large and/or tall buildings, and industrial or other premises where it is essential to remove dust, toxic or noxious contaminants at or near their source, or where high heat gains occur. System operation is the same as described previously, although the volumes of air extracted or supplied are generally higher.

Air conditioning systems further extend the role of mechanical balanced systems by allowing complete conditioning of the indoor air. In some circumstances this air provides ventilation, but in others it merely acts to transfer heating or cooling energy to a given space. Ventilation air can also be used to transport heating and/or cooling to a zone. Common configurations of air conditioning systems have been outlined below and are further detailed in Appendix A (A.1 to A.4). These systems are often incorporated into the more general HVAC system, including heating, ventilating, and air conditioning.

Modern air conditioning systems evolved from forced warm air heating and ventilation systems, with centrally located plant equipment that distributed tempered air through ducts. The addition of cooling and dehumidification equipment were found to produce sufficient air conditioning in spaces where heat gains were relatively uniform throughout the space. The presence of variable heat sources complicated these systems, resulting in the conditioned area having to be divided into sections or zones. The central system was then supplemented by additional equipment and controls. As the science of air conditioning progressed, variations in the basic designs were required to meet the functional and economic demands of individual buildings. Such configurations now include all-air, air-water and all-water systems (McQuiston and Parker, 1988).

The main goal of air conditioning systems is to provide mechanical refrigeration and/or (de)humidification in buildings located in regions that require cooling. Buildings incorporating such systems can be located in all climates, but they are the norm in hot and humid climates, for example buildings in the US Southern and East Coast States are predominantly air conditioned via central systems and roof, window, or wall units. Air conditioning is also often essential in other climate zones in large buildings subject to high heat gains.

Similar systems are used in more temperate regions of the world in both dwellings (although this is rare) and commercial developments, they are also installed in buildings for prestigious value, therefore their occurrence also depends upon the capital cost of the construction. Air conditioning equipment is expensive to install and maintain, and once installed requires the allocation of space for plant and ducting.

All of the functions of air conditioning systems (heating, cooling, humidification etc,) may not be continually active. Dwellings and commercial developments have inactive cooling and dehumidification sections during the winter months and keep the heating and humidifying sections inactive during the summer. In large commercial installations, however it is not uncommon to have all of the functions under simultaneous control for the entire year. Air is continuously circulated, cleaned and conditioned. This requires elaborate plant, controls and sensing equipment. Often buildings have hot central cores requiring heat removal while the exterior needs the heating simultaneously.

Criticisms of these systems include: improper sizing, poorly installed, operated and maintained equipment and inadequate fresh air control, resulting in a reduction of the indoor air quality. It is believed that these problems have contributed to what has become known as "Sick Building Syndrome" (SBS) and "Building Related Illness" in many commercial buildings, while legionnaires' disease is associated with buildings with improperly located and maintained water storage or cooling towers (The London Hazards Centre, 1990). Finnegan et al (1984) investigated the occurrence of SBS in a number of naturally ventilated, mechanically ventilated and air conditioned office buildings in the United Kingdom. The study found significantly more occupant dissatisfaction in buildings with air conditioning than with natural or mechanical ventilation, no direct cause was attributed to these results, although Finnegan suggests a number of possibilities.

The choice of ventilation strategy for commercial developments not only depends upon the climate of the area, although this is a consideration, especially with air conditioning systems, but on a variety of other factors. Such factors include the nature of the building itself, the size of the building (including depth and height, and number of zones). The level of occupancy and their associated activities (including the size of the heating or cooling load). HVAC systems are used not only to provide ventilation but also to facilitate cooling, and to remove excess heating loads generated by equipment and lighting. Another important consideration is the level of finance available for the development, this can be a major influence on system choices.

HVAC systems can consist of a complex arrangement of ductwork and components or be simple systems such as unitary or packaged units. A list of possible system components and their functions are given in table 5.1. The table separates the overall system into four sections, the air side, the refrigeration side, the water side and heating side. Air side components deal with the introduction of ventilation air into the building; its heating, cleaning, humidification and distribution to the conditioned space. The refrigeration side is optional, but is essentially incorporated into buildings located in hot climates; and in buildings in which high internal heat gains occur, with the plant designed to cool the ventilation air before it is distributed to the conditioned space. The water side consists of pumps and piping; and finally, the heating side consists of electric heating coils or a boiler and its associated piping system.

Table 5.1 HVAC System components.

Air Side

1. Outdoor Air Intake. (Screen, louvers, dampers)	Path for outdoor air used for ventilation and marginal weather cooling
2. Preheater	Preheats air
3. Return Air Intake (Dampers)	Path for return and/or (air washing with spray)
4. Filter	Removing contaminates from air
5. Dehumidifier (Direct spray washer or cooling coils; DX, water, brine, with or without sprays)	Cooling and dehumidifying (air washing with sprays)
6. Heating Coil	Heating in winter and reheat for temperature and/or humidity control
7. Humidifier	Humidifying
8. Fan	Air propulsion
9. Duct System	Path for air transmission
10. Air Outlet	Air distribution within air conditioned space
11. Air Terminal (With outlet)	Enclosure for air handling; may be equipped with air mixing chamber heating coil; heating and/or cooling coil; acoustic treatment, and outlet

Refrigerant Side

12. Refrigeration machine (Compressor, condenser, cooler and refrigerant piping)	Means for cooling
--	-------------------

Water Side

13. Pump	Water or brine propulsion
14. Water or brine piping	Path for transmission of water or brine between heat exchangers
15. Cooling Tower	Heat disposal from water used in condensing refrigerant

Heating Side

16. Electric heating coils or a boiler and Auxiliaries	Provides steam or hot water
17. Piping	Path for transmission of steam or hot water

Source: Carrier Handbook of Air Conditioning System Design (1965).

Several attempts to classify mechanical ventilation and HVAC systems have been outlined in Appendix A. The ASHRAE and CIBSE methods represent two professional institutions, one from the United States and the other from the United Kingdom. The Carrier classification represents a manufacturer's attempt at separating different configurations. All of these

classifications are based on the different heat transfer medium used to condition the room air. A further categorisation has recently been proposed by Knoll (1991) who restricts his examination to ventilation systems. He proposes a categorisation of systems based on room air distribution systems, this has also been reviewed for this project. This review demonstrates the wide variety of available systems, many of which are generically similar, displaying only minor differences. A brief overview of these classifications is given at the end of Appendix A.

6. A Classification of Dwelling and Commercial Ventilation Strategies and Systems

The aim of this section is to provide a brief outline to a universally acceptable classification system for ventilation systems and strategies. Such a system would update previous classifications, which date back to 1965 and combine European with North American classifications. It is not however the aim of this study to suggest new systems nor to introduce new terms, such tasks are being undertaken in a much larger study by CEN 156.

A universally acceptable classification is an important consideration, since commercial developments now involves international cooperation, not only in the design stage, but also with regard to client investment, construction, refurbishment and end use. This section therefore contains a proposed classification of ventilation systems which has been derived from the examination of the literature from the review in the previous section. It includes natural, mechanical and air conditioning systems.

Installed ventilation systems display different levels of complexity, from the natural ingress and supply of air through infiltration, windows and purpose-provided ventilation to more complex air conditioning systems, incorporating mechanical ventilation, heating, cooling, humidification and dehumidification. Several criteria can be used to classify these systems;

- The method of air movement.
- The location of the air moving equipment.
- The heat transfer medium.
- The division of supply and control.
- The degree of conditioning.
- The location of inlet outlet grilles.

Each can then be subdivided;

6.1 The method of air movement

This category summarises the methods by which ventilation air enters and leaves a building. Two main subdivisions are identified; either naturally or mechanically. These divisions contain the possible strategies commonly employed.

1) Ventilation by natural means.

- a) Infiltration.
- b) Ventilation through Windows.
- c) Ventilation through Purpose-Provided Openings.
- d) Passive Stack Ventilation.

2) Ventilation by mechanical means.

- a) Supply only (Pressurisation/Full fresh air).
- b) Extract only ventilation (Depressurisation).
- c) Supply and Extract - Balanced.
- d) Supply and Extract - Pressurised to prevent infiltration).

e) Full HVAC system. (Including heating, ventilation, cooling, humidification and dehumidification).

6.2 The location of the air moving equipment

This category identifies the location of the air handling plant, three subdivisions are recognised;

- 1) Central station or centralised mechanical system.
- 2) Unitary or packaged mechanical system.
- 3) Central fresh air with compartmentalised conditioned units.

6.3 The heat transfer medium

Four types of system can be identified under this category, with ventilation and conditioned air being supplied to a conditioned space and then tempered at terminal units located within it.

1) All-Air Systems.

- a) Single duct System.
- b) Dual duct System.
- c) Constant Volume.
- d) Variable Volume.
- e) Intermittent Run Fan.
- f) Constantly Run Fan.
- g) Terminal Reheat.
- h) Induction.
- i) High Velocity.
- j) Low Velocity.
- k) Constant Temperature.
- l) Variable Temperature.

2) Air-Water Systems.

- a) Induction Systems.
- b) Fan coil Systems.
- c) Radiant Panels.
- d) Reversible Heat Pumps.
- e) Fan Assisted VAV.
- f) Two Pipe Systems (One water supply and one water return).
- g) Three Pipe Systems (Cold water supply, Warm water supply, common return).
- h) Four Pipe Systems (Cold water supply and return and warm water supply and return).

These systems can also incorporate system change over from winter to summer mode.

3) All Water Systems.

- a) Baseboard Radiation.
- b) Free-standing radiators.

- c) Wall or Floor radiators.
- d) Bare pipe (Racked on Wall).
- e) Radiant cooling systems.

4) Direct Expansion Systems.

6.4 The division of supply and control

Supply and control can either be:

- 1) Single zone system.
- 2) Multiple zone system.

6.5 The degree of conditioning

In many installations the only difference between mechanical ventilation and air conditioning is the inclusion of mechanical refrigeration. Humidification may or may not be included since it may not be necessary to secure occupant comfort (CIBSE 1988).

- 1) None.
- 2) Heat only.
- 3) Cool only. 4) Humidify. 5) Dehumidify.

6.6 The location of inlet outlet grilles

Ceiling - Near Perimeter.
Ceiling - Internal.
Ceiling - Distributed.

External Wall - High Level.
External Wall - Low Level.

Internal Wall - High Level.
Internal Wall - Low Level.

Floor - Near Perimeter.
Floor - Internal.
Floor - Distributed.

To test the validity of the classification outlined above, and to test the assumption that the choice of ventilation system and strategy are dependent on climate and building type an international survey was conducted. The survey was distributed to all of the AIVC member countries, initially for comments and then later it was used as a basis of a international ventilation survey. The survey form has been designed to be easily completed (Appendix B). The results of this survey have been compiled and discussed in Appendix C and is based on modern commercial and dwellings in representative climates.

7. Factors to Consider When Selecting a Ventilation Strategy

The choice of which ventilation system or strategy to install or adopt should be taken at the design stage; indeed with multi-story developments, or systems requiring tight building envelopes it is essential. The selection of the ventilation system has to go alongside with the respective selection of heating/cooling system, lighting and shading etc. In this section the systems and strategies outlined in the previous sections are discussed in terms of several different criteria, each of which may play an important role in the final choice of strategy.

The discussion below is intended to promote a greater awareness of different issues relating to the design and selection of ventilation systems. The criteria have been chosen as those issues that bare most relevance to this discussion. The list is not intended to be exhaustive, but does present a beginning in the way ventilation systems are classified. By approaching ventilation system selection in this way, various characteristics and problems associated with different systems become apparent. Once these have been identified, then the task of overcoming any such difficulties can be approached. This is why it is important that ventilation systems be classified.

Several possible classifications are possible; according to:

Climate,
Goal of the System.
Building Size and Shape,
Level of Occupant Interaction,
Level of Control,
Capital Cost of the System,
Reliability, and the
Level of Maintenance Required.

7.1 Climate

The choice of ventilation system can depend heavily on the climate of an area. Climate has both implications for energy efficiency and on levels of occupant comfort.

Generally infiltration is discouraged in all climatic types; being uncontrollable, it has high energy and discomfort penalties. In mild climates natural ventilation is common, either via windows or purpose-provided vents in the building shell. In these regions the indoor - outdoor temperature difference is not severe enough to cause great concern over energy wastage. At the same time occupants have a degree of control over system operation to prevent cool draughts. Uncontrolled infiltration and ventilation through windows is not the best design approach in countries with cold climates. The indoor-outdoor temperature differences are greater providing greater concern over high energy wastage and discomfort levels. In such regions airtight building envelopes coupled with mechanical ventilation systems have been adopted. The more advanced systems incorporate heat recovery devices which ensure that these systems run at their most efficient levels.

Air conditioning systems can be installed in domestic as well as commercial premises. It can be installed into buildings in all climates, but usually they are installed to provide summer cooling in hot, humid climates and into buildings subjected to high internal heat gains.

7.2 Goal of the System

In dwellings, ventilation is necessary for basic needs, and to remove specific pollutants, namely moisture and body odour. In most cases dilution by natural ventilation and infiltration is sufficient to achieve these aims. However, in some cases the addition of extract fans to actively remove moisture or odours at times of excess production is necessary.

In commercial developments, natural ventilation may be sufficient for basic needs and to dilute office-generated pollutants in small or medium sized offices. However, in larger open plan office developments mechanical ventilation and air conditioning may be necessary, not only for basic ventilation needs, but also to remove pollutants and heating loads created by equipment, lighting and people.

Mechanical systems may be installed in smaller office complexes, as well as larger ones, to provide flexibility to the building system operation. Mechanical extract system could be integrated with natural ventilation to remove specific odours, such as those omitted for photocopies, or excessive heat loads of a computer suite.

7.3 Building Size and Shape

In small dwellings, natural ventilation for basic needs is often sufficient to maintain adequate indoor air quality, where only a few occupants are present. As the size of the building increases, the efficiency of natural ventilation to perform the ventilation task is reduced because fresh air can only penetrate and provide the necessary air flow to facilitate cooling up to about 6 to 10 metres from the outer wall. A further problem is because of floor-to-floor difference due to sites of infiltration/exfiltration where fresh air enters lower floors, but does not enter in sufficient quantities in the upper portion of the building to provide the required ventilation.

The uncontrollability and unreliability of the weather often necessitates the use of mechanical ventilation since natural ventilation would not be able to provide the necessary air flow or pollutant removal. Indoor pollutant levels can be maintained at acceptable concentrations by the use of mechanical extract systems, especially in large buildings. Zoning may be necessary in large open plan offices. Again mechanical ventilation can be controlled to accommodate such alterations. In large offices that are compartmentalised into smaller offices, natural ventilation may be used, however an essential factor is that these offices have at least one facade wall.

In tall buildings, natural ventilation is often impractical because of floor-to-floor variations and factors such as weather components, for example the higher wind speeds and associated pressures experienced at higher floors. Where a building is sheltered by either trees or buildings, natural ventilation may again be insufficient to secure adequate ventilation over a prolonged period.

7.4 Level of Occupant Interaction

All systems allow some degree of occupant interaction. Although the amount offered by various systems depends upon a number of other criteria, such as the number of occupants, the size of building and the ventilation goals. Conclusions from IEA Annex 8 which studied

inhabitant behaviour with respect to ventilation found that ventilation behaviour is related to the type of room and according to the strategy used to control the indoor environment, for example its temperature or humidity. Annex 8 stresses that it is important to give information to the inhabitants of dwellings so that they might be able to optimise their ventilation behaviour by balancing between low energy use and high indoor air quality. (IEA Annex 8, Dubrul, 1988).

Natural ventilation systems in small buildings, opening windows and vents, or the intermittent operation of extract fans provides a good degree of occupant control. Whereas with passive stack and mechanical systems the level of occupant control can be limited. Mechanical extract systems require varying levels of occupant interaction, since fans are connected to light switches, or cooker hoods. However, if occupants fail to operate these devices poor indoor air quality can result. This has led to sensor-driven versions of these systems. In large buildings, ventilation is needed to maintain a stable indoor environment either under constant or changing space heating conditions, or for the removal of a specific pollutant. In these circumstances occupant interaction is often limited. Some systems allow occupant interaction while other systems use electronic and mechanical sensors to determine correct air temperature, humidity and quality of the indoor air. Recent developments include the use of sensors to facilitate demand-controlled ventilation or in some smaller buildings the introduction of humidity-controlled vents to facilitate natural ventilation.

With respect to HVAC systems, those fitted with room air distribution terminals allow occupants to interact by altering the supply air temperature. A recent trend is to provide individual task ventilation, where air is supplied through vents in the floor directly to their desks and controlled by building occupants. However these systems require extra space for false floors and ducting.

7.5 Level of control offered by the system

The variability of the weather (wind and temperature) make natural ventilation options very difficult to control. These systems may be satisfactorily suited to small buildings with few occupants in which dilution ventilation can provide for basic needs. However, where a given pollutant needs to be removed at source, mechanical extract systems have to be installed.

With mechanical ventilation and HVAC systems, one can ensure that the correct amount of ventilation is provided. To guarantee ventilation for basic needs as well as to remove heating, lighting or occupant loads or to remove pollutant emissions, the building envelope is usually sealed using non openable windows, etc. Occupants are not in direct control of the system. The system is often regulated by indoor air quality or temperature sensors located inside and outside of the building. However, occupants may attempt to control the system by blocking supply vents which cause draughts, or building operatives may choose to limit the ventilation rate in an effort to save energy. These actions can cause indoor air quality problems.

With some systems the level of control may be deliberately limited, such as in operating theaters, where controlled air flow is essential.

7.6 Cost of the system

The cost of the system can be examined from four angles, the cost of the plant plus installation, the cost of maintenance, the cost in terms of energy efficiency and the cost to the environment.

The installation cost of natural ventilation is fairly inexpensive, indeed in the United Kingdom, the provision of natural ventilation by windows occurs by virtue that openable windows are the norm. However, windows themselves can be very expensive building components. Generally the more complicated the system, the higher the installation cost. Full HVAC systems therefore are very expensive to install and operate but can allow indoor environments to be maintained at whatever is deemed to be the comfort level, taking into account occupancy, equipment and solar loads.

Generally the more complex a system, the more it is going to cost to maintain its operation. Windows and simple passive systems are easily to maintain, usually by the building owners/occupier. However mechanical and HVAC systems often have to be maintained by qualified engineers as well as energy managers. Such maintenance is very often an additional overhead. Failure to regularly maintain these systems could lead to a variety of problems including many of the symptoms associated with Sick Building Syndrome.

In terms of energy efficiency, natural ventilation options are the least efficient. The loss of energy via infiltration and exfiltration through building envelopes can amount to a high energy penalty if the ventilation air has to be conditioned (heated or cooled). On the other hand, the losses by infiltration must be balanced against the cost of the system. Mechanical ventilation may be a viable option if heat recovery can be installed and infiltration reduced. This demands a centralised point of exhaust air to allow for the heat extraction (or coolth extraction).

However, the severity of the climate is one of the main determining factors, as well as the efficiency of heat recovery devices. If the differences between indoor and outdoor temperatures is sufficient to allow enough energy to be recovered then balanced mechanical systems may be economic. However at present they are only considered economic in Scandinavia and Canada.

The ecological/environmental cost is becoming increasingly important, the choice of ventilation heating/cooling system etc may have unseen environmental costs, which will come under increasing scrutiny. For example the Montreal Protocol has called for reductions in Chlorofluorcarbon (CFC) emissions (Butler, 1989). Such developments have resulted in many so called new "Green" designs which incorporate natural ventilation strategies.

7.7 Reliability

In terms of reliability, infiltration and natural ventilation are the least reliable options. They depend upon temperature and wind speed to drive the air into and throughout the building and on optimum sizes of openings. Mechanical ventilation and HVAC systems are in theory more reliable, since they are capable of supplying or extracting the required air to or from the space in order to remove a given pollutant or provide desired fresh air for comfort and health. However, poor installation and maintenance may lead to a deterioration in their performance,

for example infrequent replacement of filters may lead to poor indoor air quality and unless the ducting is kept clean the system can actually degrade indoor air quality.

7.8 Maintenance level

This category is associated with system reliability, in that natural ventilation systems are essentially low on maintenance. However poor quality windows and vents will lead to high levels of infiltration and discomfort. Also to be considered is the introduction of dust and dirt since filters are not part of these systems. The more complicated the system, the greater the level of maintenance. Failure to provide adequate levels of maintenance results in reduction in the efficiency of the system. Natural ventilation systems can be adequately maintained by building occupants, as can small scale mechanical and HVAC systems. Large commercial HVAC systems have to be maintained by qualified personnel to ensure an efficient working system (without proper training and documentation, maintenance problems are common in such systems).

7.9 User friendliness

The expression "User friendliness" is used to convey how the occupant perceives the systems and its ease of use. Many complaints relating to Sick Building Syndrome and other Building Related Illnesses have been linked to air HVAC systems (Finnegan et al, 1984, Raw G 1989).

Tong (1984) has stated the greater the building complexity, the less control the user has over their environment, and the more uncomfortable they feel. Tong goes on to state that in large naturally ventilated buildings occupants have little control, since they have to consult a large number of people before they open a window. While in large deep plan office buildings where air conditioning is needed to remove heat gains and provide ventilation to interior zones occupants have little real control over their environments. Occupant complaints in such buildings are greater than those in naturally and mechanically ventilated buildings.

Mechanical ventilation and more complex systems can be both user friendly or not. If individual room controls are provided, then occupants feel they can control the ventilation and air quality level. However, in large buildings this form of control would be impractical if each individual changed the setting, since a large number of people would be affected by such changes. This depends on the number of people in the room and whether "cold persons" clash with "hot persons". In separate rooms or work stations individual control of temperature is the ideal approach.

It should be noted that systems can be designed for "user friendliness" but systems once realised have to be checked for user acceptance. Users may judge systems differently to what the designer considered to be user friendly.

The criteria discussed in this section is not designed to be exhaustive, but to promote further thought to how ventilation systems can be characterised. It is only when the pros and cons of these systems are clearly identified that they can be improved.

8. Conclusions

It is clear that the energy crises have had a significant effect on the building and ventilation practices in today's modern buildings. Improvements in the thermal performance of buildings has included greater levels of thermal insulation and the specification of airtightness standards. Reducing excessive ventilation rates by the introduction of minimum requirements sufficient for basic needs has also helped reduce unnecessary energy consumption.

The combined effects of conservation measures has not only reduced excessive levels of infiltration heat losses, but as a consequence made the pollutant removal capacity of the ventilation air less effective. In dwellings such lower ventilation rates have led to a greater occurrence of condensation, and higher pollutant concentrations. High moisture levels result in lower indoor air quality but the resultant condensation causes structural damage to many building fabrics. In response to these problems natural and mechanical extract ventilation systems have been installed in some buildings. In other buildings, local extract fans or higher natural ventilation through windows has been advocated at times of excessive moisture emission. Vapour barriers are used to restrict vapour diffusion and air exfiltration through the envelope.

Lower ventilation rates can also increase the accumulation of a number of potentially harmful pollutants within the indoor environment. Such concentrations are believed to be responsible for a variety of occupant illnesses, including cancer and also be a contributing factor to Sick Building Syndrome. More recent research has also demonstrated that a variety of new pollutants from new materials are also being emitted within indoor spaces. The response to these increasing levels of pollutant concentrations has been slow, with the majority of current ventilation requirements still being specified to provide for basic occupant needs. Such rates may be insufficient to remove the growing number of indoor pollutants. However, the role of ventilation in minimising the impact of increasing pollution must also be questioned. Care must be taken in the introduction of pollutants (source control) and extract fans need to be placed where sources are present (local removal) before relying on ventilation as a means of contaminant control.

These problems have pointed out that we must know the interaction between specified airtightness and ventilation rate requirements, and different ventilation strategies, if the balance between adequate ventilation and conservation measures is to be optimised. The level of control over the ventilation process is therefore of vital importance. Limb (1992) found that the level of permissible control available depends on economic factors, which can in turn can be related to the severity of the climate. These relationships appear strongest in the case of dwellings, although in some smaller commercial developments the choice of ventilation systems is also climate related.

Table 8.1, which summarises the results of the international survey outlined in section seven. From this table it can be seen that thirteen out of the fourteen countries examined in this study have a temperate climate in at least part of the country. In dwellings in these regions, natural ventilation is still used. These systems vary in complexity from openable windows, where ventilation is mainly accidental, to passive stack systems which harness the temperature and pressure effects of natural forces to extract room air while outdoor air is supplied via purpose-provided openings within the building envelope. In five of these countries natural, passive systems have been converted to mechanical extract systems to give even greater

ventilation control. Infiltration has been restricted in all of these instances but has not been eliminated.

Table 8.1

Country	Climate	Ventilation and Airconditioning Systems	
		Dwellings	Offices
Belgium	Temperate	Openable Windows Passive Stack Mechanical Extract	
Canada	Polar (North) Boreal	Controlled Natural Mechanical - Balanced	
Denmark	Temperate	Controlled Natural	
Finland	Temperate	Passive Stack Mechanical Extract Mechanical - Balanced	Mechanical - Balanced Central Station Air Water Multizone
France	Temperate Subtropical	Passive Stack Mechanical - Balanced Mechanical Extract	Openable Windows Mechanical - Balanced Extract Only Central Station/ All Air/ Air Water
Germany	Temperate	Openable Windows	Mechanical - Balanced Central Station All Air All Water Multizone
Italy	Temperate Subtropical	Openable Windows	Mech. Balanced Pressurised Central Station All Water Multizone
Netherlands	Temperate	Openable Windows	Mechanical - Balanced Central Station All Water Air - Water Multizone
New Zealand	Temperate Subtropical	Openable Windows	
Norway	Temperate Polar Boreal	Passive Stack Mechanical Extract Mechanical - Balanced	
Sweden	Temperate Boreal	Passive Stack Mechanical - Balanced	
Switzerland	Temperate	Passive Stack	Mechanical - Balanced Central Station All Water
UK	Temperate	Openable Windows	
USA	Temperate Polar Subtropical Tropical	Openable Windows Air Conditioning	Mechanical - Balanced Central Station Extract Only All Air All Water Multizone

In colder climates (classified as Boreal and Polar), well-designed natural ventilation systems formed the historical base for what now is dominated by mechanical ventilation systems. Heat recovery devices are incorporated into mechanical systems, can be an economic option. Where the climate is classified as (Sub)Tropical, openable windows, mechanical ventilation and air conditioning systems are all common ways of providing the necessary ventilation required for cooling.

Larger commercial buildings ventilate for basic needs, to control heat gains and to remove indoor pollutants. The choice of ventilation strategy in these cases are not necessarily climate related, with the choice of large mechanical ventilation and air conditioning systems being determined more by client and designer preference, cost, building design, type and function. This is especially true in temperate regions. However, in (Sub)Tropical regions air conditioning is necessary to ensure occupant comfort.

The overall aim of this study was to examine ventilation systems and strategies and different ways of classifying them. From the review of systems and strategies in Appendix A, the classification outlined in section 6 has been devised. Based upon an investigation of the literature, much information with regard to dwellings exists, however, the same is not true of commercial buildings. Therefore to test the validity of the proposed classification and gather more information relating to commercial ventilation and HVAC systems an international survey was conducted.

Replies indicate that balanced, air-water/all-air, central station, and multizone ventilation systems are most common in commercial applications. The most common configuration is single duct, constant volume, variable temperature, low velocity system. However, only seventeen replies were received and thus a more extensive survey is needed to give a true representation of the most commonly used systems throughout the countries reviewed.

Despite this shortcoming, this study has succeeded in categorising ventilation systems and strategies used within dwelling and commercial buildings; and its use in successfully identifying these strategies in fourteen different countries indicates its wide applicability and usefulness in future studies. In section nine, several alternative ways of classifying ventilation strategies were examined. The criteria used to classify these systems provide a initial framework in which to base further discussion and thought.

9. References

- AIVC (1981), Building Design for Minimum Air Infiltration. 2nd AIVC Conference. Proceedings. Held at Royal Inst. of Tech. 21 - 23 Sept. 1981.
- ASHRAE (1987) HVAC and Applications Handbook. pp 2.1 - 5.8. American Society of Heating, Refrigerating and Air Conditioning Engineers, 1791, Tullie Circle, Atlanta, GA 30329.
- ASHRAE (1989) Fundamentals Handbook. pp 23.1 - 23.20 American Society of Heating, Refrigerating and Air Conditioning Engineers, 1791, Tullie Circle, Atlanta, GA 30329.
- ASHRAE (1992) HVAC Handbook. pp 1.1 - 6.6. American Society of Heating, Refrigerating and Air Conditioning Engineers, 1791, Tullie Circle, Atlanta, GA 30329.
- Bekker J (1991), Requirements on installation performance. Proceedings of a Workshop held Lausanne, Switzerland, 27-28 May 1991, Brussels-Luxembourg, ECSC-EEC-EAEC, Publication No. EUR 137766 EN of the Commission of the European Communities, Scientific and Technical Communication Unit, Directorate General Telecommunications, Information Industries and Innovation, Luxembourg, pp 227-238.
- Bienfait D (1990), Design of ventilation systems in residential buildings. UK, AIVC 11th Conference, "Ventilation System Performance", held 18-21 September 1990, Belgirate, Italy, Proceedings published March 1990, Volume 2, pp 41-52, 7 figs, 7 refs.
- Bjornevad B and von Post J (1990), Air to air heat pumps for directly electrically heated houses. Sweden, Swedish Council for Building Research, Stockholm, report R60:1990, 33pp.
- Breum N O and Skotte J (1992), Displacement ventilation in Industry - a design principle for improved air quality. UK Building and Environment. Vol 27 No 4 1992, pp 447-453.
- British Standards Institute (1991), BS 5925 Code of Practice for Ventilation and Designing for Natural Ventilation.
- Brunsell J T, Skaret E (1989), Infiltration and ventilation developments in Norway. in: UK, AIVC, 10th AIVC Conference, held at Espoo, Finland, 25-28 September 1989, Volume 2, February 1990, pp 311-331, 14 figs, 10 refs. #DATE 00:02:1990 (#3592)
- Butler D J G (1989) BRE Information Paper. CFCs and the Building Industry. IP 23/89. November 1989. Building Research Establishment. Garston, Watford, UK
- Carrier handbook (1965), Handbook of Air conditioning system design. Pub. McGraw Hill. pp 9-1 - 12-19.
- CIBSE (1988), Volume A Design Data. Section 4. Air Infiltration and Natural Ventilation. Pub. Chartered Institute of Building Services Design
- CIBSE (1988), Volume B Installation and Equipment Data. Section 3. Ventilation and Air Conditioning. Pub. Chartered Institute of Building Services Design

- Chen Q, Moser A and Suter P (1992), A Database for Assessing Indoor Airflow, Air Quality and Draught Risk. Swiss Fed. Inst. of Tech. Zurich, Energy Systems Lab. Zurich, Switzerland. Airflow Atlas, IEA/ECB Annex 20, April 1992.
- Dubrul C (1988), Inhabitant behaviour with respect to ventilation - a Summary report of IEA Annex 8. UK, Air Infiltration and Ventilation Centre, Technical Note 23, March 1988, 61pp.
- Edwards (1991), The Shape of Things to Come. pp 48-49. CIBSE Journal May 1991.
- Elmroth and Levin (1983), Air Infiltration Control in Housing - A Guide to International Practice. Swedish Council of Building Research. AIVC Handbook.
- Etheridge D W (1982), Natural ventilation in the UK and some considerations for energy efficient design. 3rd AIVC Conference, Sept. 1982, London UK.
- Fimmegan M J, Pickering C A, Burge P A (1984), The sick building syndrome: prevalence studies. British Medical Journal. Vol 289. Dec 1984. pp 1573-1575.
- Gids De W F (1984), Philosophy and background of the Dutch standard for air tightness of dwellings. 5th AIVC Conference Oct. 1984, Reno Nevada USA.
- Grot R A and Persily A K (1983), Air infiltration and airtightness tests in eight US office buildings. 4th AIC Conference "Air infiltration reduction in existing buildings" Switzerland, 26-28 September 1983 p.11.1-11.26 16 figs. 13 tabs. #DATE 26:09:1983 in English
- Guntermann K (1992), Air quality improvement using a displacement ventilation system. Roomvent '92. Third International Conference, Aalborg, Denmark, September 2 - 4 1992, Pub.DANVAK, Lyngby, Denmark, Vol 3, pp369-380.
- Hamlin T, Forman J, Lubun M (1990), Ventilation and airtightness in new detached Canadian housing. Canada, Mortgage and Housing Corporation, May 1990, 24pp, 23 figs, 11 tabs, 14 refs.
- Harrje D T Hunt C M Treado S J Malik N J (1975), Automated instrumentation for air infiltration measurements in buildings. Princeton University, Centre for Environmental Studies, report no. 13
- Hartmann P J Widder F (1989), Infiltration and ventilation in Switzerland - Past and future. 10th AIVC Conference, Dipoli Finland. [#3594]
- Hekmat D, Feustal H, Modera M P (1986) Impacts of ventilation strategies on energy consumption and indoor air quality in single-family residences. Energy Bldgs, Vol 9, No 3, August 1986, p239-251, 3 figs, 4 tabs, 17 refs.
- IEA (1986), Energy Perspectives, Chapter 4, IN Energy for Buildings - Microprocessor Technology. International Energy Agency, Paris.
- Jardinier P and Simonnot J (1990), Principle and aim of a Natural Humidity-Controlled Ventilation System. Societe AERECO, Collegien - France.

- Kadulski R (1990), Construction Practices: Pulse builder survey results. Solpan Review, April-May 1990.
- Knoll B (1992), Advanced ventilation systems - state of the art and trends. UK, Air Infiltration and Ventilation Centre, Technical Note 35, March 1992, 100pp.
- Kohonen R (1990), Demand controlled ventilation systems for dwelling-houses of the future. UK, AIVC 11th Conference, "Ventilation System Performance", held 18-21 September 1990, Belgirate, Italy, Proceedings published March 1990, Volume 1, pp 55-78, 6 figs, 6 tabs, 12 refs.
- Kronvall J (1990), Air infiltration and ventilation. Progress and trends in Sweden. in:UK, AIVC, 10th AIVC Conference, held at Espoo, Finland, 25-28 September 1989, Volume 2, February 1990, pp333-344, 1 tab,14 refs. [#3593]
- Limb (1992), The Development of a Methodology for the Categorisation of Ventilation Strategies. MPhil Thesis Pub. 1992.
- Limb (1993), A Review of Current Airtightness, Ventilation and Measurement Requirements. AIVC Technical Note January 1994
- Lstiburek S (1991), Wood frame construction: Do we build them like we used to. IN Solplan Review. June - July 1991, pp 6-8.
- Lyberg M D (ed)(1987), Source book for energy auditors. IEA Energy Conservation. App C. Energy use and auditing problems. pp91-178. IEA Annex 11 - Energy Auditing, Voll.
- McQuiston F and Parker J (1988), Heating, Ventilating and Air conditioning. - Analysis and design (3rd edition). Pub. Wiley and sons.
- Mertz G (1992) Chilled Ceilings and Ventilation Systems. Thermal Comfort and Energy Saving. Pub. AIVC Air Infiltration Review. Vol 13, No 3 June 1992.
- O'Sullivan P and Jones P J (1982), The Ventilation Performance of Houses - A Case Study. 3rd AIVC Confer. Energy Efficient Domestic Ventilation Systems for Achieving Acceptable Indoor Air Quality. Sept. 20-23 1982, London, UK.
- Railio Jorma (1984), Better Airtightness: Better or Worse Ventilation. 5th AIVC Conference, Oct 1984. Reno Nevada USA. [#1585]
- Riberon J, Millet J Z (1992) Draughts due to air inlets: an experimental approach in : "Ventilation for Energy Efficiency and Optimum Indoor Air Quality", 13th AIVC Conference, Nice, France 15-18 September 1992.
- Riberon J, Villenave J G, Millet J R (1993) Evaluation of Mechanical Domestic Ventilation Systems: The French Approach. Indoor Air '93 Conference, Helsinki, Finland 4-8 July 1993.

Riley M, Lawton M (1990), Air infiltration in Canadian homes a decade of change. in:UK, AIVC, 10th AIVC Conference, held at Espoo, Finland, 25-28 September 1989, Volume 2, February 1990, pp253-267 25 refs. [#3588]

Robinson T (1990), Moisture challenges in Canadian efficient housing. CMHC, Ottawa. [#4333]

SCANVAC (1991), Classified Indoor Climate Systems - Guidelines and specifications. Edited Swedish Indoor Climate Institute.

Schmickler F P (1988), Examinations about the air humidity in lived dwellings depending on different air ventilation systems using a new characteristic value. in: "Effective Ventilation", 9th AIVC Conference, Gent, Belgium, 12-15 September, 1988. #DATE 00:09:1988

Sherman M. (1984) Description of ASHRAE's proposed air tightness standard. 5th AIC Conference ' The implementation and effectiveness of air infiltration standards in buildings' Reno, Nevada 1-4 October 1984 [#1587]

The London Hazards Centre, 1990). Sick Building Syndrome - Causes effects and control. June 1990. pp 48 - 55 Pub. London Hazards Centre Trust Limited.

Tong D (1989), Intelligent and Healthy Buildings. Design for environmental quality '89. Conf. Held at British Gas, West Midlands, Solihull. 21-22 September 1989.

Trepte L (1985), Air quality and energy conservation by different ventilation systems. 6th AIVC Conference, September 1985, Netherlands. [#1787]

Uglow C E (1989) Background ventilation of dwellings - a review. UK, Garston, Watford, Building Research Establishment report BR 162, 1989, 9pp.

Wouters P et al (1988), Ventilation and air quality in Belgian buildings: A state of the art. 9th AIVC Conference, Gent, Belgium. 1988.

Youle A (1991), Building services engineering and the control of substances hazardous to health (COSHH) regulations. UK, Chartered Institution of Building Services Engineers, 1991, CIBSE National Conference 1991, held at University of Kent, Canterbury, 7-9 April 1991, pp 192-200, 2 figs, 10 refs. #DATE 00:00:1991 in English

Appendix A

A.1 ASHRAE Classification of Air Conditioning Systems

The American Society of Heating Refrigerating and Air Conditioning Engineering (ASHRAE) have also developed a categorisation of ventilation and air conditioning systems, (ASHRAE 1987, 1992) based on the nature of heat transfer medium. This is outlined below;

1. All-Air Systems

A) Single-Duct Systems

- I Constant Volume Systems**
 - i Single Zone Systems**
 - ii Multi-zone reheat systems**

II Variable Volume Systems

- i Reheat**
- ii Induction**
- iii Fan Powered Systems**
- iv Dual Conduit Systems**
- v Variable Diffusers**

B) All-Air Dual Duct Systems

- I All-Air Dual Duct Systems**
 - i Constant Volume**
 - ii Variable Volume**

II All-Air Multizone Systems

- i Constant Volume**
- ii Variable Volume**
- iii Three Deck or Texas Multizone**

2. Air-Water Systems

- A) Induction**
- B) Fan Coil**
- C) Radiant Panel**

(The distribution system for each of the above is either: 1) Single Pipe Systems ,
2) Two Pipe System, 3) Three Pipe System, 4) Four Pipe System)

3. All-Water Systems

- A) Baseboard Radiation**
- B) Free Standing Radiators**
- C) Wall or Floor Radiant**
- D) Bare Pipe (Racked on Wall)**

4. Unitary Refrigerant Based Systems.

These systems are further explained below;

1) All-Air Systems

In all-air systems, conditioned air is supplied from a central plant room by a network of ducts. Room air is removed and either returned to the plant for recirculation or exhausted directly outside. Two configurations of these systems have been identified; single and dual duct systems.

A) Single Duct Systems

These systems utilize a central air handling plant and one duct to supply all room terminal units air of the same temperature.

Two basic types of all air, single duct systems have been identified: Constant and Variable volume.

I) All-air, single duct, constant volume systems

These systems supply a constant volume of air to room terminal devices. The temperature of the supplied air is altered in response to room loads at the central plant room. Three variations exist:

- i) Single-zone systems** These systems can be located in or outside of the conditioned space and may operate with or without distribution ductwork, supplying air to a single temperature control zone. A return or relief fan may be needed, depending on the capacity of the system and whether 100% outdoor air is used for cooling at some time during the year.

- ii) Multi-zoned reheat systems** Cold primary air or recirculated room air is distributed from terminal reheat devices, located within the conditioned space. By operating the reheat coil the supplied air temperature can be varied.

- iii) Bypass** A bypass box can be used instead of a reheat coil, operating as a constant volume primary air system, with a VAV secondary system. The volume of air supplied to the terminal unit remains constant, but the volume of air supplied to the space is varied in response to the changing room loads. The excess supply air is dumped into the return ceiling plenum or return air duct, thereby bypassing the room.

II) All-air, single duct, variable air volume systems

Centrally conditioned air is supplied to the space, VAV diffuses within the space regulate the volume of air supplied. In this way the temperature of the space is controlled. Cooling is achieved by either increasing the volume of air through the system or by supplying cooler primary air. A number of configurations can be further identified:

- i) Reheat** these systems incorporate reheat devices in the terminal units. Usually applied to systems requiring full heating and cooling flexibility in interior and exterior zones.
- ii) Induction systems** these systems use terminal units to reduce the cooling capacity by reducing primary air while at the same time inducing room or ceiling air to maintain a relatively constant room supply volume.
- iii) Fan powered systems** parallel and series configurations are available. In parallel flow units, the fan is located outside the primary airstream to allow intermittent fan operation. In series units, the fan is located within the primary air stream and runs continuously when the zone is occupied.
- iv) Dual conduit systems** these systems are designed to supply two air supply paths. The primary airstream operates as a constant volume system, and the air temperature is varied to offset transmission only. The secondary airstream is cool year round and varies in volume to match the load due to gains from the sun, occupants and equipment.
- v) Variable diffusers** These systems reduce the discharge capacity of the diffuser, keeping the discharge velocity relatively constant while reducing the conditioned supply airflow. Under these conditions the induction effect of the diffuser is kept high and cold air mixes in the space. Two types of diffuser are common, one has a flexible bladder which expands to reduce the aperture, and the other has a diffuser plate that is physically moved. Both are pressure dependent, being either system powered, pneumatically powered or electrically driven.

B) All-air, dual duct systems

These systems utilize two ducts to supply room terminal devices with cold and hot air. Two variations exist;

I) All-air, dual duct systems

Separate cold and warm air duct distribution systems supply and blend the air at the terminal devices.

- i) Constant Volume** Outdoor and recirculated air are supplied at a constant volume and then blended at the room terminal device before entering the room.
- ii) Variable Volume** Outdoor and recirculated air are blend in various volume combinations and then supplied to the room.

II) All-air, multizone systems

Multi-zone systems supply several zones from a single, centrally located air handling unit. These systems utilize a separate supply air duct to each zone, with the supply air blended to the required temperature at the main unit mixing dampers.

- i) Constant Volume** These systems operate similar to those outlined above.
- ii) Variable Volume** These systems operate similar to those outlined above.
- iii) Three Deck or Texas Multizone systems** In these systems the warm air heating coil is removed from the air handler and replaced with an air resistance plate matching the pressure drop of the cooling coil. Individual heating coils are then placed in each perimeter zone duct only. Zonal conditions are maintained by the mixture of supply and return air in the central air handling units. Heat is only added if the zone temperature cannot be maintained by the delivery of return air alone.

All-air systems may be adapted to many applications for comfort or process work. They are used in buildings that require individual control of multiple zones, such as in offices; schools; hospitals, etc. All-air systems are also ideal for special applications requiring close control of temperature and humidity such as clean rooms, computer rooms, hospital operating rooms, etc.

2) Air-Water Systems

Primary air is supplied to room terminal units and not only provides ventilation air, but also induces room air to pass over water heating or cooling coils. The resulting tempered secondary air is then introduced to the space. Room terminal units are either induction, fan coil or radiant panel units.

A) Induction systems

B) Fan coil systems

C) Radiant panel systems

The distribution systems are either:

- i) Single pipe systems**
- ii) Two pipe systems**
- iii) Three pipe systems**
- iv) Four pipe systems**

The most common configurations for air-water systems are single pipe, where one pipe supplies primary water from the plant room to the terminal devices, and then returns the

secondary water back to the plant room. In two pipe systems, one pipe supplies, and a separate pipe returns the water to and from the terminal devices.

The quantity of primary air is fixed, and the air temperature varies inversely with outside temperature. Transition from summer operations to intermediate season operation is done by gradually raising the primary air temperature as the outdoor temperature falls to keep rooms with the same cooling loads from becoming too cold. The secondary water remains cold throughout the summer and intermediate seasons. As the outdoor temperature drops further, the changeover temperature will be reached. The secondary water circuit can then be changed over to provide hot water for heating.

Three pipe systems have separate cold and warm water supply and a common return pipe. These systems are rarely used today as they are considered inefficient. Four pipe systems have separate cold water supply, and return pipes and warm water supply and return pipes. The terminal water unit having two independent secondary water coils, one served by hot water and one being served by cold water. The primary air is cold, and remains at the same temperature year round.

3) All-Water Systems

All water systems heat and/or cool the space by direct heat transfer between water and circulating air. Hot water systems deliver heat to a space by water that is hotter than the air in contact with the heat transfer surface. Hot or cold water is circulated through either of the four radiant systems below:

A) Baseboard Radiation.

B) Free standing radiators.

C) Wall or floor radiant.

D) Bare pipe (racked on wall).

If all-water systems include cooling as well as heating, they must move air by forced convection through the conditioned space, filter the circulating air and introduce outside ventilation air. Fan coil terminal units are designed for this purpose.

4) Unitary Refrigerant-Based Systems

Unitary systems are self contained units, which draw fresh air into each zone directly from outside. They are located on an external wall or window, and may supply air directly to the space or for larger units via a ducted distribution system. These units take several forms including window air conditioners; through-the-wall room air conditioners; unitary air conditioners, for indoor and outdoor locations, and air and water source heat pumps. The components are factory assembled into an integrated packages, including, fans, filters, heating coil, cooling coil, refrigerant compressors and controls.

A.2 CIBSE Classification of Air Conditioning Systems

The Chartered Institute of Building Service Engineers (CIBSE) in the United Kingdom have also categorised mechanical ventilation and air conditioning systems, (CIBSE 1988, volumes A and B), and have noted that many air conditioning systems may be regarded as mechanical ventilation systems, if the cooling coils were omitted. The CIBSE identify three categories of system, according to different heat transfer medium.

- 1) All-air systems.
- 2) Air-water systems.
- 3) Unitary systems - Refrigeration plant.

These systems can be further sub-divided according to the division of supply and control. The two basic groups recognised are; single and multi-zone, with respective systems being assigned to each division. Single zone control is where the conditioned space is controlled as one zone. This is appropriate where the loads of a building or conditioned space are "in phase". Multi-zone is adopted in cases where building loads are "out of phase". A deep plan office would be an example of an out-of-phase building, where the perimeter is subject to high solar gains, while the interior is not, having fairly constant loads. Both require ventilation and air conditioning, but their requirements differ. Systems falling into the above three categories are outlined below and are further explained in the following sections.

1. Direct Expansion Systems

2. All-Water Systems

- A) A Single, 2 pipe system
- B) Multi-pipe System

3. All-Air Systems

- A) Constant Volume, Variable temperature Systems
 - i Induction
 - ii Multi Zone Unit Systems
 - iii Dual Duct Systems

B) Variable Volume, Constant Temperature Systems

C) Dual Conduit Systems

4. Air-Water Systems

- A) Induction Units
- B) Fan Coil Units

1) Single Zone Systems

A) Full fresh air

These systems consist of an outdoor air inlet, humidification, heating and cooling batteries and a fan, as shown in the figure below. Outdoor air enters the system and is tempered in order to maintain comfort conditions within the conditioned space. Temperature and humidity

sensors located in the space control the amount of conditioning required. Room air is exhausted directly to the outside.

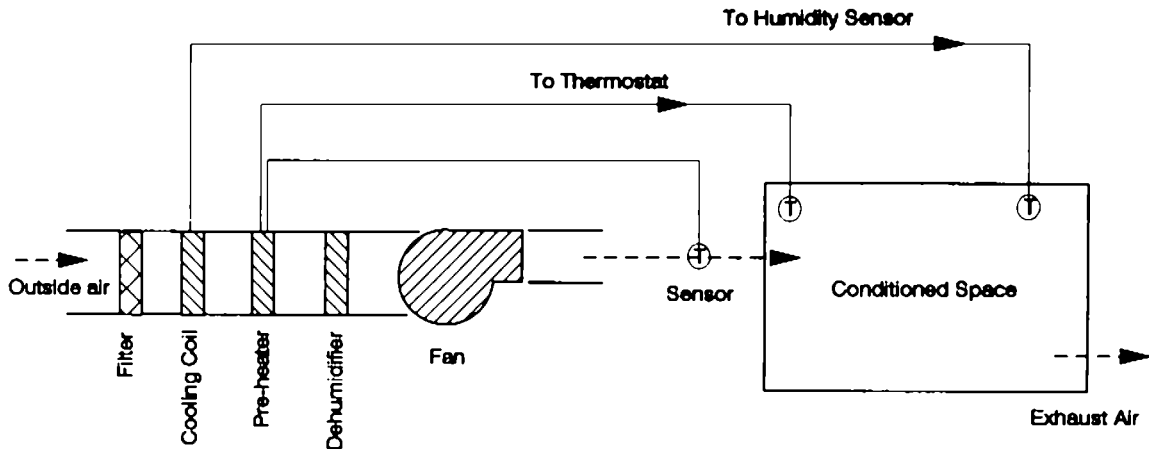

Figure A2.1 Full Fresh Air Systems.

B) Recirculation

These systems replicate the full fresh air system, with the addition of recirculation. A proportion of the exhausted room air is returned to be mixed with incoming outdoor air. Typically, only sufficient outdoor air is used to secure ventilation for basic needs. This is then added to the recirculated air. If the conditions within the space deteriorates, the proportion of outdoor air to recirculated air is changed, with more of the room air being exhausted. A schematic of the system is shown in figure A2.2

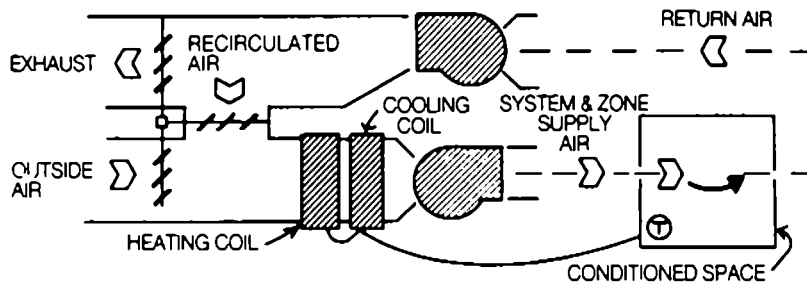

Figure A2.2 Single Zone; Recirculation Systems. Source: Source Book for Energy Auditors, IEA Annex 11, 1987 (Lyberg (ed.)).

2) Multiple Zone Systems

A) All-Air Systems

The principles of all air systems have been described in section A1 above. The sub-divisions outlined below discuss various methods of changing or introducing the tempered air into the conditioned space.

- i) **Multi-zone, all-air, terminal reheat systems** Centrally treated air is distributed at a common temperature and humidity to reheat terminal devices located within the

conditioned space. These reheaters are activated by sensors located within the conditioned space. Should any overcooling occur in any zone the respective terminal reheater is activated. To reduce unnecessary reheat, control signals from the reheater sensor, can be analysed centrally, the resulting schedule for the off-coil sensor being based on the zone requiring the lowest supply air temperature, i.e. minimum reheat requirement.

ii) Multi-zone, all-air, variable air volume (VAV) systems

The temperature of the space is controlled by varying the supply volume of air, rather than its temperature. Centrally treated air is supplied to terminal devices within the room. These are usually located in the ceiling. Cooling is achieved by either increasing the volume of air through the system, operating a chilled water distribution system, or by supplying cooler primary air. The variation of air flow is controlled by diffusers within the room. VAV systems can be applied to both interior or perimeter zones with common or separate fan systems, air temperature control and with or without additional heating appliances.

Three basic VAV systems exist;

a) Induction VAV systems. Primary air is discharged at a constant volume through induction nozzles or slots at the variable volume supply outlet. These systems are a hybrid between basic VAV and dual duct systems. The volume of primary air quantities reduces with load, thus retaining the diversity of VAV, while the individual room process blends cold primary air with recirculated ceiling plenum air (ASHRAE, 1987 HVAC volume).

b) Fan assisted VAV. A fan within each terminal VAV unit is used to increase room air movement. This causes a greater movement of air through a space at low cooling loads and during reheating, compared to VAV reheat or perimeter radiation systems. Terminal units can be parallel or series configurations. In parallel units, the fan sits outside the primary airstream to allow intermittent fan operation. While in series units the fan sits in the primary airstream and is continuously operated when the zone is occupied.

c) Dual Duct VAV systems. These systems blend cold and warm air in various volume combinations. Operating as a basic VAV system, at full volume the system can deal with the maximum cooling load in each zone. As the cooling load reduces the damper in the cold duct is closed. The warm air damper is kept closed until the cooling VAV damper reaches its maximum setting. A further reduction in cooling load is dealt with by operating the warm air damper.

iii) Multi-zone, all-air dual duct systems

Warm and cold air are supplied to a mixing terminal unit located within the conditioned space. The two air streams are blended inside the unit in response to zonal temperature sensors, before then being introduced into the space.

iv) Multi-zone, all-air hot deck/cold deck systems

These systems are similar to the dual duct systems except that zonal mixing of the two air streams occurs in the central air handling plant. This allows low velocity distribution of

conditioned air. These systems are best suited to applications having a number of zones and with centrally located plant. Although the interaction between separately controlled zones having different flow requirements can cause problems, the figure below is diagrammatic representation of such a system.

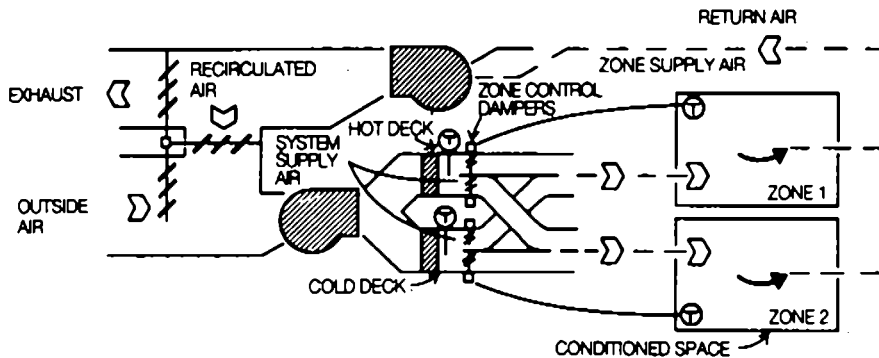

Figure A2.3 All-Air; Multizone System. Source: Source Book for Energy Auditors. IEA Annex 11, 1987 (Lyberg (ed.))

B) Air-Water Systems

Air - water systems consist of a centrally located air handling plant, supplying conditioned air to induction or fan coil units. The sub-divisions outlined below discuss various methods of changing or introducing the tempered air into the conditioned space.

- i) Multi-zone, air - water, induction systems** Primary air is supplied to the room terminal induction units by a high pressure fan. This primary air is then discharged at high pressure through nozzles within the unit thus providing ventilation air and the motive force for inducing room air into the unit. Induced air then passes over the water heating or cooling coils. These systems have been dealt with in more depth by Carrier section A3.
- ii) Multi-zone, air - water, fan Coil systems** Centrally tempered primary air is supplied to fan coil units located within the conditioned space. A fan induces room air into the unit which is then mixed with primary air. This mixture then passes over a heating or cooling coil and finally passes into the room.
- iii) Multi-zone, air - water, reversible heat pump systems** Air - water reversible heat pumps can operate as heat pumps to provide heating or alternatively as direct expansion (DX) coolers (See section A3.1, Carrier Classification). The reversible heat arrangement consists of a refrigerant/room air coil, a refrigerant/water heat exchanger, a compressor, an expansion device and a reversing valve.

When heating is required, the air coil becomes the condenser, heat is drawn from the water circuit, then upgraded by the compressor. When cooling is required the air coil becomes an

evaporator, rejecting heat to the water circuit via the water side condenser. Figure A2.5 shows a possible configuration of such a system. Therefore simultaneous heating and cooling may be provided to different zones when required. These systems are not appropriate for hot and humid climates where high cooling water temperatures are inevitable.

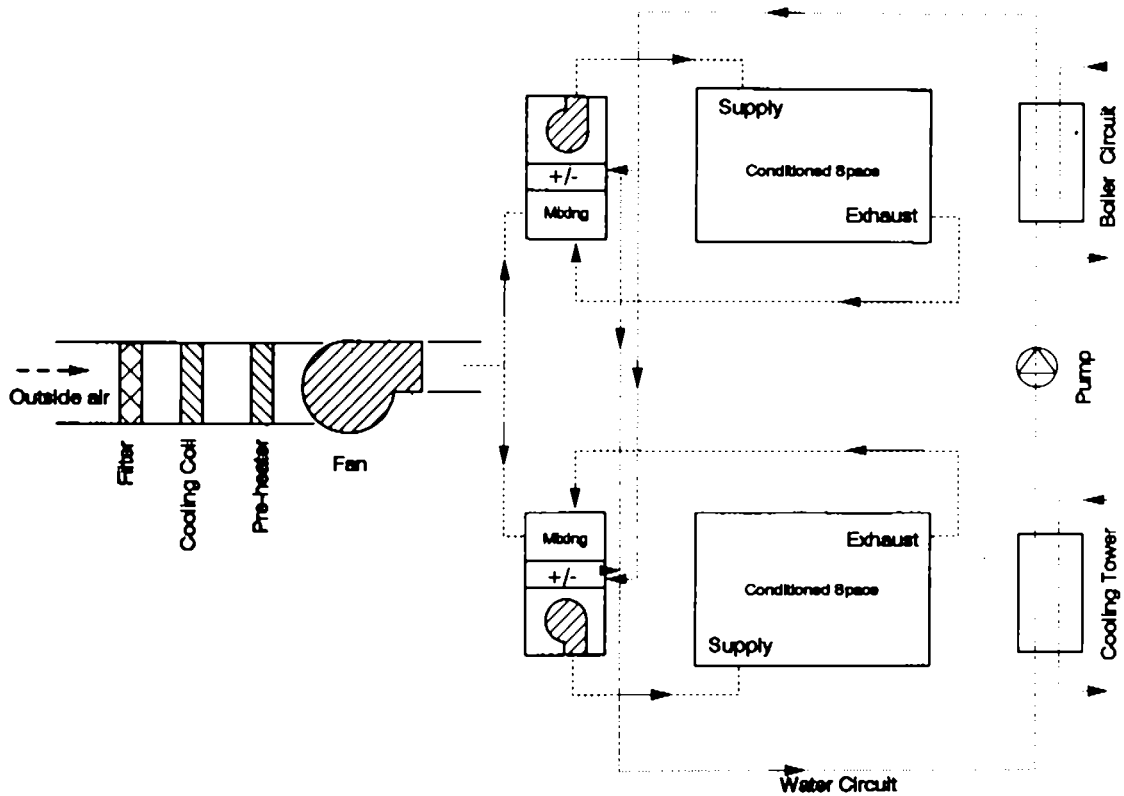

Figure A2.4 Air-Water; Multi Zone, Reversible Heat Pump Systems.

iv) Various multi zone air/water units

a) Chilled Ceiling systems.

Chilled water pipe work circulates above a suspended ceiling. Cooling is limited by the minimum allowable chilled water temperature (which must be above the maximum dew point of the room air to avoid surface condensation) and the heat transfer characteristics of the ceiling. These systems are used to control the zonal heat gains from solar radiation and occupants. While structural and lighting gains etc. are dealt with by ventilation.

The response of this system is slow, and depends upon the ceiling area. Ventilation air should be balanced against outside air for zones where perimeter transmission is significant. Three possible configurations of these systems are shown in figure A2.5 below.

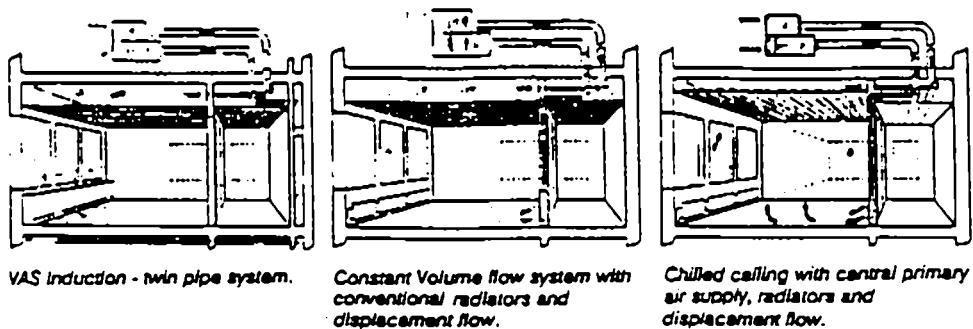

Figure A2.5 Air-Water; Chilled Ceiling Systems. Source: Mertz (1992)

b) Unitary Systems.

Unitary systems are self-contained units, which draw fresh air into each zone directly from outside. They are located on an external wall or window, and may supply air directly to the space or for larger units via a ducted distribution system.

c) Fan Coil Units.

The operation of these units have been described above. Fan coil units located in different zones should be able to deal with both fresh air and dehumidification loads. This will result in coils running wet for some of the time. Provision should therefore be made to remove any condensation that may result. Humidification, if required would need to be achieved by separate means (for example, by injection of vapour direct into the room). Output from the heating and cooling coils is regulated by a temperature sensor connected to the water flow valves. The fan should not be used to achieve temperature control, since the fresh air levels must be maintained for constant occupancy.

d) Reversible Heat Pumps.

With these systems the fresh air quantity is limited to a fixed value, typically 20 to 25% of supply. (See section A3 Carrier Classification).

e) Room Air Conditioners.

Room air conditioners are packaged units consisting of a room air side evaporator (DX cooling coil), an outside air cooled condenser, a compressor and an expansion device. Winter heating is often an electric coil, although a low pressure hot water coil is another option. These units are also known as "window units" or "through the wall" air conditioners.

f) Split Systems.

These systems consist of a room air conditioner, or small air handling unit, incorporating a DX cooling coil. This plant is connected to a remote air or water cooled condensing unit, via

low pressure vapour and high pressure refrigerant lines. In the smaller units control is achieved by activating the compressor, while in larger units DX coils may incorporate refrigerant flow control.

A3 Carrier Classification of Air Conditioning Systems

The Carrier classification has remained unchanged since the mid 1960s, and represents the oldest of the examined classifications. Four types of system are identified in the Carrier handbook (1965), based on the criteria of the heat transfer medium, in DX systems a direct refrigerant is used, while the remaining configurations either water or air or both are utilised. These systems are outlined below;

1. Direct Expansion Systems (DX).
2. All - Water Systems
 - A) A single - 2 Pipe Systems
 - B) Multi - Pipe Systems
3. All - Air Systems
 - A) Constant Volume, Variable Temperature.
 - i Induction Units
 - ii Multi - Zone Unit Systems
 - iii Dual Duct Systems
 - B) Variable Volume Constant Temperature Systems
 - C) Dual Conduit Systems
4. Air - Water Systems
 - A) Induction Units
 - B) Fan Coil Units

1) Direct Expansion Systems (DX)

Direct Expansion Systems (DX) are self-contained cooling units, consisting of outdoor and return air intakes, a filter, fan and air outlet. Refrigeration is achieved by the use of a compressor, condenser, and cooler, with a direct refrigerant (such as R22 (Chlorodifluoromethane) as the heat transfer medium. Outdoor and room air are cooled as they pass through the refrigeration equipment. Diagram A3.1 shows how cooling is achieved using these systems.

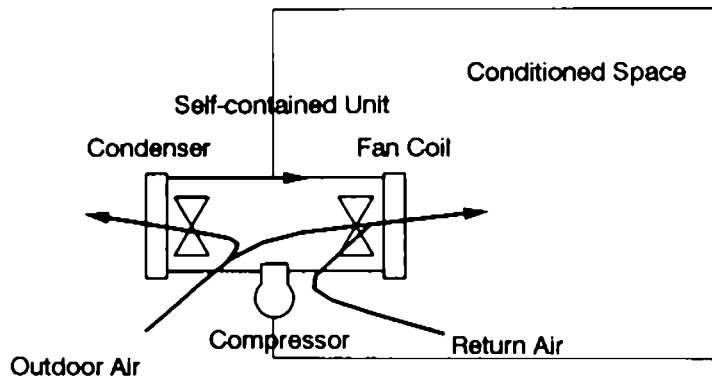
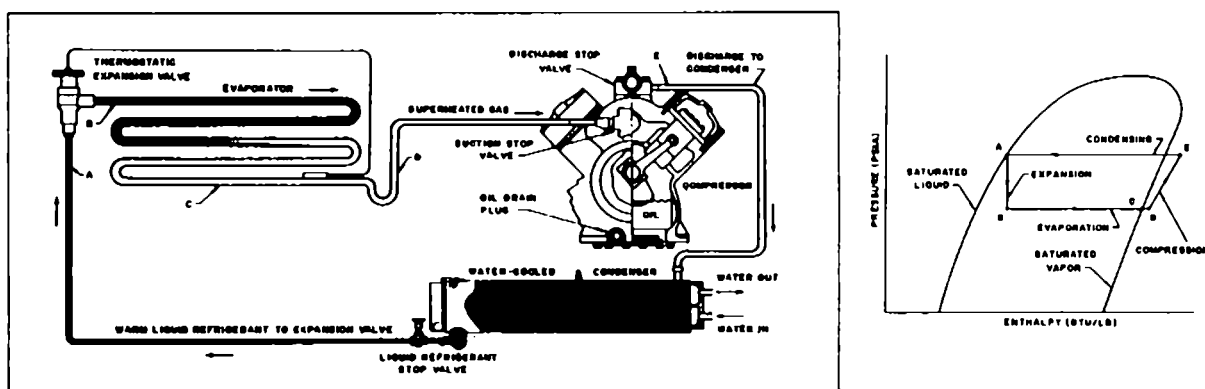

Figure A3.1 A Direct Expansion System.

A positive displacement compressor (a reciprocating compressor, for instance) draws in super heated refrigerant gas, from the fan coil unit. The compressor raises the gases temperature and pressure, this increase in pressure causes the gas to flow to the condenser. Outdoor air is then forced through the condenser by a fan. This air absorbs the heat of the hot refrigerant gas causing it to condense (From E to A on the inset diagram). The liquid refrigerant is then collected and passed through a fan coil unit (Point B on the diagrams below) . Another fan then forces warm outdoor and recirculated room air over the cooling coils. Heat transfer occurs between the air and the refrigerant, resulting in cool air being introduced into the space, while the super heated refrigerant (C), is then passed back to the compressor (D). These processes are shown in the diagram and inset below.



*Figure A3.2 Reciprocating Compression Refrigeration Cycle.
Inset: Pressure Enthalpy Diagram - Compression Cycle. Source: Carrier (1965).*

Direct expansion units represent the simplest form of summer air conditioning system, being located near or within the conditioned space itself. Variations can include the addition of a pre-heater, for winter operation, or the addition of a heat pump, which can turn these units into year-round systems.

DX units can be used in small and large rooms and segregated zones, including private residences, offices, commercial establishments or in a group of offices in a single zone.

2) All-Water Systems

In all-water systems chilled water or brine is supplied from a central refrigeration plant and circulated through coils of an air terminal unit (usually fan coil unit, see figure A3.3) within the conditioned space. Outdoor and room air are introduced directly into the unit, and forced over the cooling coils. The heat transfer medium (water or brine) is warm in winter to provide heating.

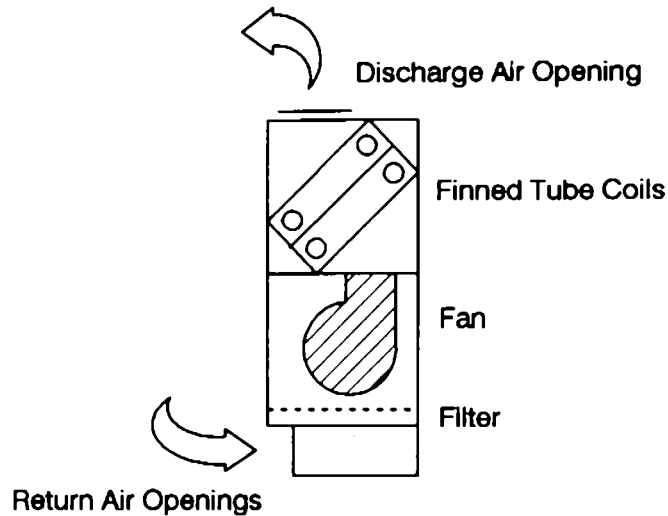

Figure A3.3 A Typical Fan Coil Unit.

Two configurations of these systems are identified:

- A) A single, 2-pipe system operates as outlined above, with temperature control being maintained by adjustments to the speed of the fan or water flow. These systems provide individual room temperature control and restrict recirculation to the conditioned space.
- B) In multi-piping systems both hot and cold water are supplied to each fan coil unit. Return water can either be via one common or two separate pipes. These units allow a quick response to thermostat settings and all year round temperature control. Multi-pipe systems allow several room terminal units to be connected within one zone. This eliminates the need for multiple pumps, zoned piping and allied controls. All water systems can be used in smaller multi-room buildings, such as factory/office buildings, motel/hotel rooms and hospitals etc.

3) All-Air Systems

In all-air systems, conditioned air is supplied from a central plant room by a network of ducts. Room air is removed and either returned to the plant for recirculation or exhausted directly outside. Three configurations can be identified:

A) Constant volume; variable temperature systems

These systems maintain comfort conditions by varying air temperature and humidity, while the volumetric amount of supply air remains the same. This can be achieved in the central air handling plant or in the conditioned space, three methods of achieving this control are outlined below.

i) Induction units

A constant volume of cool conditioned air is supplied to the unit. This so called primary air handles the entire room requirements for cooling, dehumidification humidification and ventilation. The primary air induces room air which is heated by the coil to provide summer cooling (when needed) and winter heating. Room temperature control is achieved by adjusting the flow of hot water or steam through the coil, either manually or automatically. A schematic of a typical induction unit can be

seen in figure A3.4 below, while figure A3.5 shows the configuration of the whole system incorporating the induction unit.

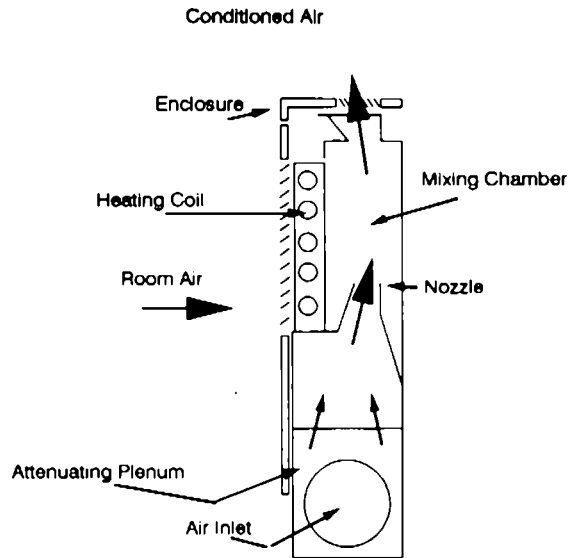

Figure A3.4 A Typical All Air Induction Unit.

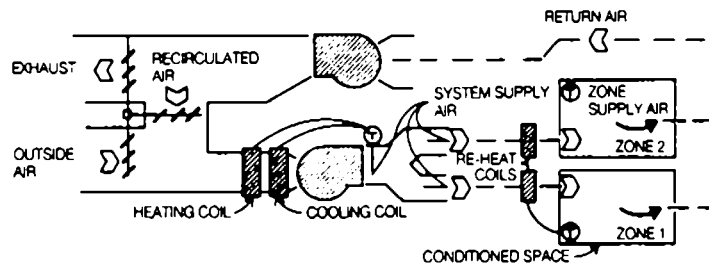

Figure A3.5 An All-Air; Constant Volume; Variable Temperature Induction System. Source: Source Book for Energy Auditors. IEA Annex 11. 1987 (Lyberg (ed.))

ii) In a multi-zone unit system a single duct transmits the conditioned air directly to the space. A typical configuration of such a system is shown in figure A3.6. Individual zone thermostats control the mixing dampers in the plant room. These systems are most applicable where several large or small spaces need to be individually controlled such as in a school, or suite of offices. Other applications include where the area consists of interior spaces with individual load characteristics, or where the area includes zones of differing exposures.

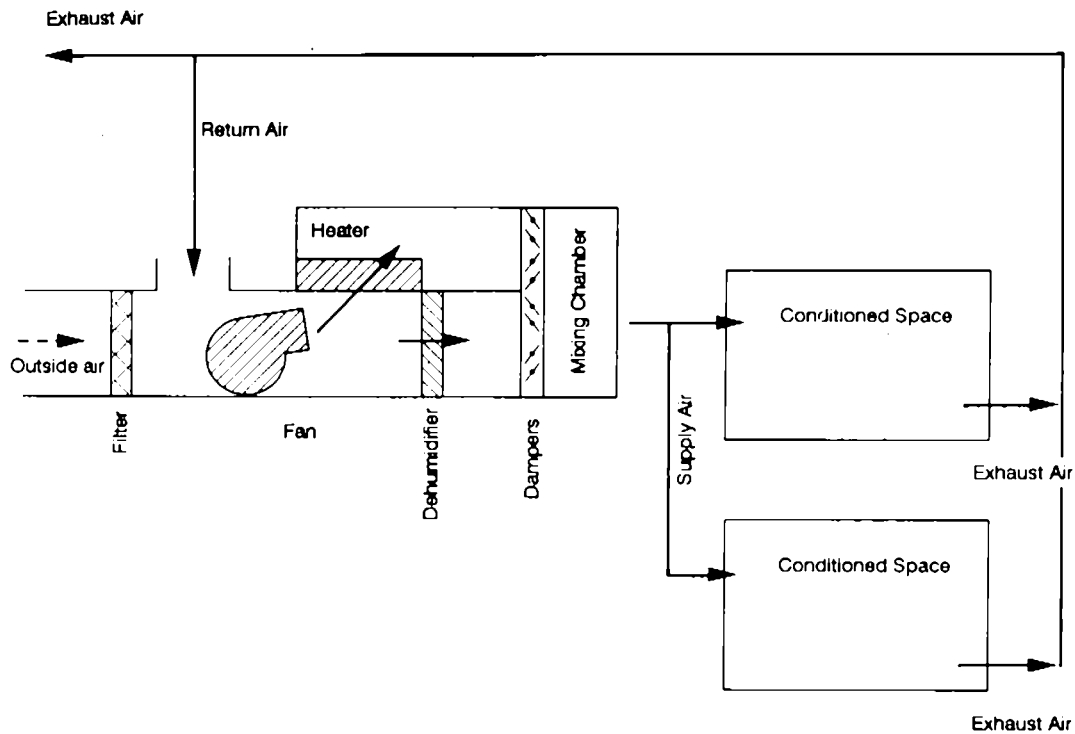

Figure A3.6 (a) All-Air Constant Volume; Variable Temperature; Multi-Zone Unit System.

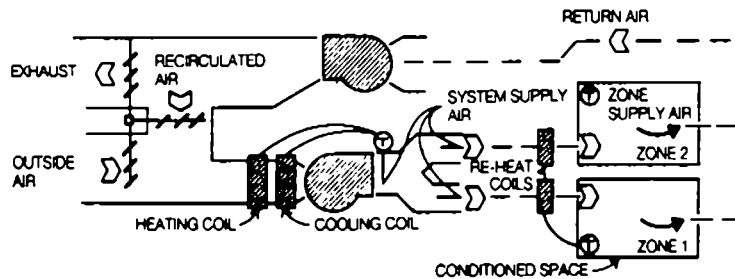

Figure A3.6 (b) All-Air Constant Volume; Variable Temperature; Multi-Zone Unit System with Terminal Reheat. Source: Source Book for Energy Auditors, IEA Annex 11, (Lyberg (ed.).

iii) In dual duct systems, (figure A3.7) a mixing terminal unit located within the space is supplied with both warm and cold air. The two air streams are mixed in the unit in response to a thermostat setting, before being introduced into the space.

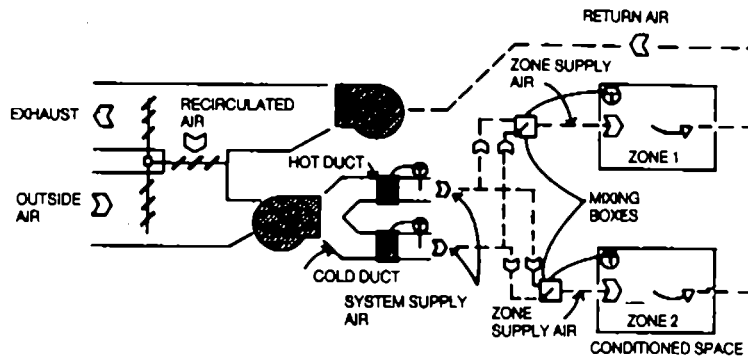

Figure A3.7 All-Air Constant Volume; Variable Temperature; Dual Duct System. Source: Source Book for Energy Auditors, IEA Annex 11, (Lyberg (ed.))

B) Variable volume; constant temperature systems

Air volume control is applied to either the individual branch ducts or the individual outlets. The space conditions are maintained by room thermostats controlling the volume of supply air to the space. To be completely effective over the complete range of load variations the Carrier handbook (1965) states the supply air terminal must be able to maintain reasonable air circulation within a space and must without condensation occurring at the outlets. Figure A3.8 shows a typical system layout. These systems are well suited to provide temperature control to individual spaces or zones. They can be used for multi-zone buildings, where a relatively constant cooling load exists all year round, such as the interior zones of office and department stores. These systems are unsuitable for the exterior zones of these buildings since the solar gains represent a major portion of the system load.

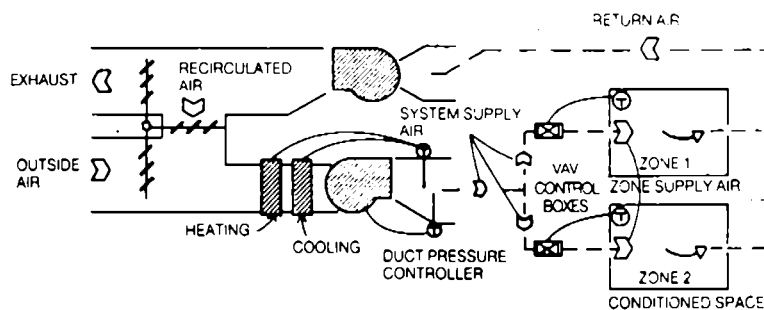

Figure A3.8 All-Air Variable Volume; Constant Temperature Systems. Source: Source Book for Energy Auditors, IEA Annex 11, 1987, (Lyberg (ed.))

C) Dual conduit systems

These systems (diagrammatically depicted in figure A3.9) combine variable volume; constant temperature and constant temperature variable volume systems. Two central air handling units condition two air streams and supply them separately to room terminals. These two air streams are known as primary and secondary air respectively. Primary air is a mixture of outdoor and return air, while secondary air is a mixture of outdoor air and return air or all

outdoor air, depending upon the season. The secondary air stream has a constant, cool temperature and variable volume to match the changing capacity required for the varying loads. The primary air stream is of constant volume, and air temperature is varied to offset transmission effects; warm in winter, cool in summer. A refrigeration and heating plant is necessary to complete the system. Terminal units can be located in several places, with secondary units being mainly located in the ceiling of the space, while primary units can be located either in the ceiling or under a window or side wall. The conditioned space may consist of several zones or of a single zone. Dual conduit systems are applied within defined areas of usually constant, but occasionally variable occupancies for example interior office and factory spaces.

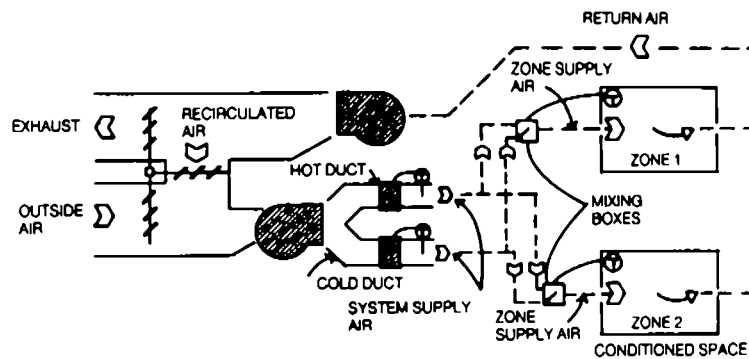

Figure A3.9 All-Air; Dual Conduit System With Dual Fan. Source: Source Book for Energy Auditors, IEA Annex 11 (Lyberg (ed.)) 1987

4) Air-Water Systems

Air-water systems consist of a centrally located air handling plant, supplying conditioned air to induction or fan coil units.

A) Induction units

Centrally conditioned primary air is supplied via ducts to the room terminal units by a high pressure fan. This primary air is then discharged at high pressure through nozzles within the unit, not only providing ventilation, but also the motivating force for the induction and circulation of room air. The high pressure discharge of primary air induces room air to be drawn across the cooling or heating coils. These coils are supplied with chilled water or brine from a central refrigerating plant room. The induced air is tempered according to the relative temperatures of water and primary air, after passing over the coils the induced air is supplied to the space. Most of the rooms' thermal load is balanced by warm or cooled water circulated either through a coil in an induction unit or through a radiant panel. The figure A3.10 shows a section through a typical air-water induction unit, while figure A3.11 shows how these units are incorporated into the completed system.

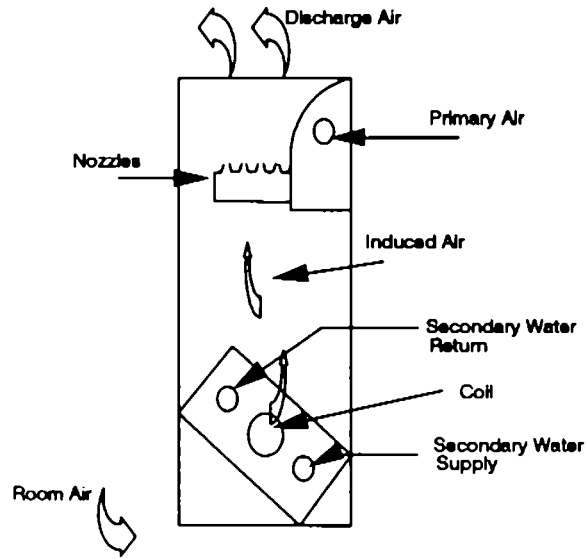

Figure A3.10 Typical Air-Water Induction Unit.

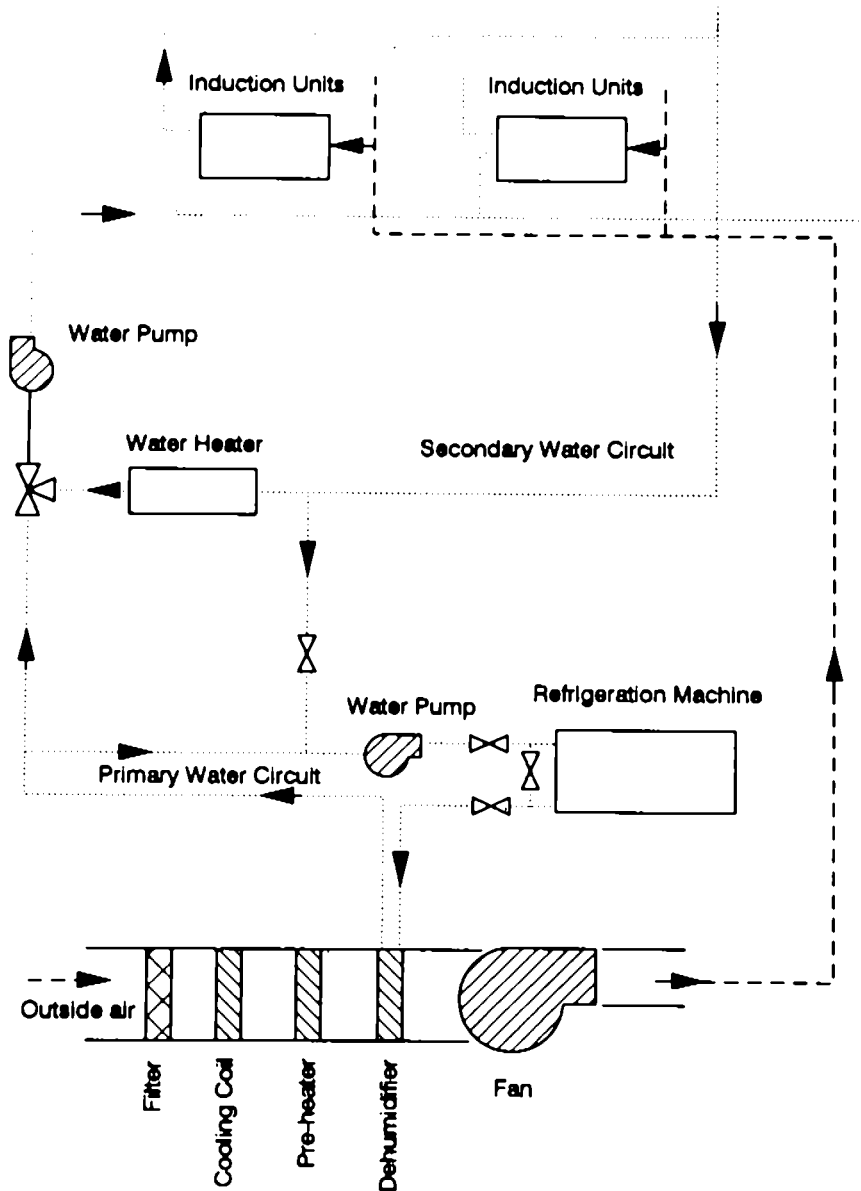

Figure A3.11 Air-Water Induction Unit System. Induction unit systems are designed for use in perimeter rooms of multi-story, multi-room buildings such as offices, hotels and hospital rooms.

B) Fan coil units

Centrally tempered primary air is supplied to fan coil units located within the conditioned space. A fan induces room air into the unit which is then mixed with primary air. This mixture then passes over a heating or cooling coil and is finally discharged into the space. Hot or cold water supply the coils to provide the desired temperature control. Figure A3.12 shows a section through a typical air water fan coil unit, while figure A3.13 demonstrates how these units can be included into a complete air water system.

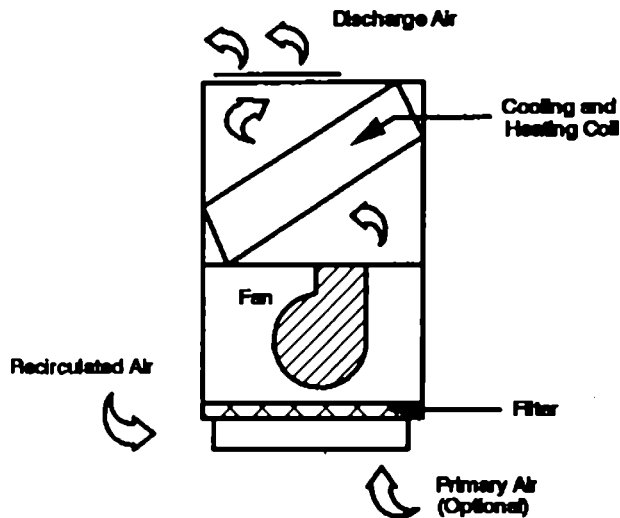

Figure A3.12 Typical Air-Water Fan Coil Unit

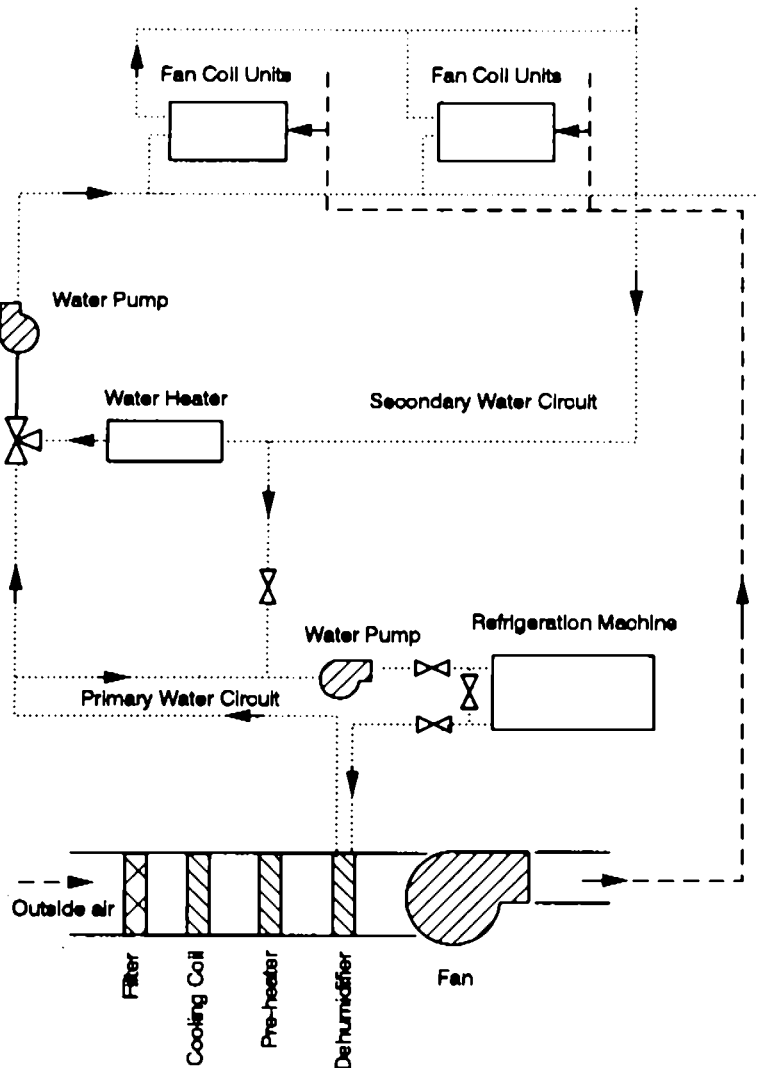

Figure A3.13 Air-Water Fan Coil Unit System.

Air water systems can also incorporate automatic or manual system change-over from winter to summer mode. Automatic operation utilises a thermostat coupled to a change over switch. When specified set-point temperatures are reached, the system operation changes.

Heat pumps can be incorporated into any of the above systems to allow year round air conditioning. Heat pump systems have been extensively reviewed in ASHRAE (1992).

A4 Knoll's Classification of Ventilation Systems

The previous three classifications outlined above have been based on essentially the same criteria, separated with regards to the heat transfer medium, (i.e., all-air, all-water etc). However Knoll (1991), attempted to classify ventilation systems on the basis of the room air distribution systems. These systems provide ventilation air and aim to remove specified pollutants, by extraction or supply of ventilation air to specific locations within the conditioned space.

Knoll's classification is outlined in Table 3.2. By using five criteria to categorise different ventilation approaches, he has proposed the classification outlined below, in which he identifies five main categories of ventilation system;

1. Air movement Control Systems.
 - A) Spot flow control Systems.
 - i Local exhaust systems.
 - ii Jet flow systems.
 - iii Enforced local exhaust systems.
 - iv Localised ventilation systems.
 - B) Internal room flow control systems.
 - i Mixing ventilation room systems.
 - ii Displacement ventilation systems.
 - iii Forced vortex ventilation systems.
 - C) Inter-room control systems.
 - i Natural exhaust duct system with controlled supply.
 - ii Mechanical exhaust controlled supply systems.
 - iii Mechanical supply systems.
 - iv Balanced mechanical ventilation systems.
 - v Overflow ventilation systems.
 - D) Dwelling in-or outflow control systems.
 - i Radon or methane mitigation systems.
 - ii Vapour mitigation systems.
 - iii Combustion ventilation systems.
2. Flow Control Systems.
 - A) Automatic set point maintenance systems.
 - i Temperature controlled natural supply.
 - ii Pressure difference controlled natural supply.
 - iii Pressure difference controlled mechanical supply.
 - B) Automatic set point adjustment systems.
 - i Presence dependent mechanical ventilation.
 - ii Carbon dioxide and odour controlled ventilation.
 - iii Temperature controlled ventilation.
3. Ventilation Heat Recovery Systems.
 - A) Air to air heat recovery.
 - B) Air to heat pump systems.
 - C) Heat recovery air supply windows.
 - D) Dynamic wall heat recovery.

4. Alternative Ventilation Energy Gain Systems.
 - A) Soil heated or cooled ventilation air.
 - B) Solar heated ventilation air.

A fifth category is also considered, Air Cleaning and Recirculating Systems, but Knoll considers it only applicable for industrial premises and not for households.

The methodology Knoll adopted for the classification outlined above is based on the development of an objective measurable rating system. The aim was to classify systems to give the potential ability of a ventilation system to use a minimum of energy for getting an acceptable indoor air quality, without annoyance. This rating system examines five criteria;

- Application of ventilation flows linking the location, the production and the flow pattern of pollutants;
- Energy input or recovery;
- Cost of installation and operation;
- Reliability (durability and chance of disorders);
- Effect on comfort.

Knoll has chosen to approach the classification of ventilation systems from a different angle than previous classifications, his proposed classification system is based on the ability of the ventilation air to remove polluted air. The emphasis of this classification is on room air distribution system which calls mainly for sealed rooms or buildings, with mechanical ventilation. It does not therefore bring together the aspects of climate and building type, merely the function and aim of providing ventilation. He identifies existing and novel ventilation approaches into five further categories.

- 1 Background or intermittent ventilation.
- 2 Separate room or central ventilation.
- 3 Displacement flow.
- 4 Natural or mechanical ventilation.
- 5 Heat recovery or Alternative energy gain.

Categories 1, 2 and 3 do not rely on the external climatic conditions to be effective, but on the nature and location of pollutant sources within the building. Ventilation is provided to remove selective pollutants usually occupant generated from a space. While categories 4 and 5 relate the external climate with the type of ventilation approach adopted. The choice between natural or mechanical ventilation is dependent upon the severity of the climate among other considerations. Countries suffering from severe winter temperatures have adopted mechanical ventilation approaches, because of their ability to control flows better and to apply heat recovery. In moderate and mild climates heat recovery is hardly cost effective, consequently the simpler and cheaper natural ventilation systems or mechanical exhaust systems are still preferred. Category five has already been touched upon, with the application of air-to-air heat recovery or air-to-heat pump systems being more profitable in severe climates. Although Knoll does point out that improvements in the efficiency of these devices could also promote their use in more moderate climates. He also notes that ventilation for basic needs may no longer be adequate, since tests have indicated that the provision of adequate ventilation may in fact be significantly higher. This is not only due to occupant behaviour, but also to changes in building materials. Higher pollutant concentrations has promoted additional ventilation,

which in turn has imposed an additional energy load. The size of this load depends on the level and efficiency of this additional ventilation. Research into estimating the likely size of this load and possible reduction strategies is already underway, for example IEA annex 18 (Raatschen, 1990) was set up to study Demand Controlled Ventilation Systems. While IEA annex 8 (Dubrul, 1988) showed through tests that additional ventilation decreases with lower outside temperature.

APPENDIX B

Ventilation and Air Conditioning Survey Form.

International Survey of Ventilation Strategies

(If you wish to give a more detailed answer to any point, then please use the back of this form, or a separate piece of paper, thank you.)

A) General Information

Contact.....
 Company Name.....
 Address.....

 Tel..... Fax.....

Building Description

Building Type (Residential/Industrial/Commercial).....
 Building Address.....

 Number of rooms and/or zones.....

Total volumetric size of these rooms and/or zones.....

What is the fresh air requirement of the system?

Has a conscious decision been made to design to an airtightness specification. If so please specify airtightness standard.....

Is the building sealed or does it have openable windows.....

Type of ventilation -
 Natural []
 Mechanical []
 Natural/Mechanical []

B) Design Parameters

	Internal Temp.(°C)	Internal RH (%)	External Temp.(°C)	External RH (%)
Winter				
Summer				

Is the ventilation system designed for :

- (i) Local dispersion control (eg Local extraction) . []
- (ii) Displacement ventilation. []
- (iii) Mixing ventilation. []
- (iv) Maintenance of a pressure hierarchy. (eg Difference in pressure prevents mixing of contaminants). []

Is the aim of the ventilation system :

- (i) Basic ventilation (Control of pollution due to normal human activities). []
- (ii) Control of solar heat gains. []
- (iii) Removal of excess moisture due to washing etc. []
- (iv) Removal specific contaminants. []
- (v) Removal of combustion products. []
- (vi) Others (Please specify.....).

What ventilation standard /building regulation was used: -

Fresh air requirement.
 Air change rate.

Why did you choose the particular system for the building.....

[Continued overleaf.....]

C) System Classification

1. Classification according to the method of air movement.

- (i) Supply only ventilation (Pressurisation/Full fresh air). []
- (ii) Extract only Ventilation (Depressurisation). []
- (iii) Supply and Extract - Balanced. []
- (iv) Supply and Extract - Pressurised to prevent infiltration). []

2. Classification according to the location of the air moving equipment.

- (i) Central station, or centralised plant room. []
- (ii) Unitary, or packaged plant. []
- (iii) Central fresh air with compartmentalised conditioned units. []
- (iv) Other (Please specify.....)

3. Classification According to the Heat Transfer Medium.

- (i) All-Air system. []
- (ii) Air/Water system. []
- (iii) All Water system. []
- (iv) Direct Expansion System. []

4. Classification according to division of supply and Control.

- (i) Single zone system. []
- (ii) Multiple zone system. []

5. Classification according to the degree of conditioning of the air.

(Tick [✓] more than one box.)

- (i) None []
- (ii) Heat only []
- (iii) Cool only []
- (iv) Humidify []
- (v) Dehumidify []

6. Classification according to the location of the inlet/outlet grilles.

Please read all six classification, and tick [✓] any boxes which are appropriate

		Inlet	Outlet
Ceiling	Near Perimeter		
	Internal		
	Distributed		
External wall	High level		
	Low level		
Internal wall	High level		
	Low level		
Floor	Near Perimeter		
	Internal		
	Distributed		

D) System Details

In order to provide more detail, classification 3 above has been further subdivided. Please tick all boxes which are appropriate. [More than one box may be chosen].

	Primary air	Secondary air
Single duct system		
Dual duct system		
Constant vol.		
Variable vol.		
Intermittent run fan		
Continuously run fan		
Terminal reheat		
Inductuction		
High velocity		
Low velocity		
Const. temp.		
Variable temp.		

[Continued overleaf.....]

APPENDIX C Ventilation and Air Conditioning Survey Replies

C1. The Results of an International Survey of Ventilation Strategies and Systems

The information obtained from this survey has been used to provide a review of the current ventilation systems used in a sample of modern buildings within AIVC member countries. Buildings reviewed in the technical press, are often unique, non-typical, incorporating new and revolutionary ideas. This survey attempted to examine typical commercial office buildings within the AIVC member countries. Seventeen replies were received in answer to the survey these are selected from Germany, Finland, The Netherlands, Italy, Switzerland and the United States of America. Information has also been received from Sweden and Canada regarding dwelling ventilation systems.

A) and B) General Information and Design Parameters.

This section examines the general features of the building and its location.

All replies to the survey discuss commercial office buildings. All have mechanical ventilation and some have HVAC systems. The ranges of design internal and external temperatures are outlined below for both winter and summer:

Internal Winter Temperature Range From 20 to 26 Deg. C

Internal Summer Temperature Range From 20 to 28 Deg. C

External Summer Temperatures Range From 25 to 35 Deg. C

External Winter Temperatures Range From -40 to +8 Deg.C

Internal comfort temperatures in Europe and North America are limited to a narrow range for both summer and winter (between 20 and 28 Deg. C) in order to maintain thermal comfort levels. External temperatures show a much larger variations, from -40 C in winter to +35 Deg. C in summer. In some parts of the USA, Las Vegas for example, temperatures can reach up to 45 Deg. C. This verifies the need for either summer cooling or winter heating. The extremes in climate indicate a need for buildings in many countries to have tight building envelopes. This is to reduce infiltration losses in winter, while in summer high solar loads are restricted, and mechanical refrigeration is used to provide the necessary cooling. Infiltrating hot, humid summer air (encountered in many areas of the USA in summer) must be limited. About half of the southern United States' AC load is humidity related. In only a few instances do both external temperature extremes occur in the same regions. Therefore most buildings are designed for either one extreme or the other. For example in New York temperatures can range between -18 Deg. C for the coldest winter day to +37 Deg. C for the hottest summer day, with some summers experiencing more than 30 days at temperatures of 32 Deg. C or higher. Where both extremes are experienced, HVAC systems must meet both heating and cooling requirements.

Questions relating the design philosophy are also contained within this section. A common application for systems is to achieve mixing ventilation, 70% of the replies described systems designed for this purpose, including all of those from Finland and most of those from the United States. Displacement ventilation although most commonly found in Scandinavia, has been identified in three of the seventeen replies, in both Germany and the United States. Displacement ventilation is regarded as the most efficient form of ventilation, where the ventilation air acts as a piston, pushing the "old" room air in front of it without mixing. Forty seven percent of replies include systems designed for more than one purpose, these include all of the German systems, the Dutch system, and four of the US systems. The most common goal was local pollutant dispersion control (for example, local extraction systems) and mixing ventilation.

The choice of ventilation strategy depends not only on the external climate or economic cost of energy but also of the building type and the reason for providing ventilation. The ventilation strategy may have more than one aim, the five most common strategies have been identified by Knoll (1991) and have been included in this survey. The most common reason is providing ventilation for basic needs, with all reported systems designed for this purpose. Forty seven percent of replies discuss systems designed just for this purpose, while twenty nine percent of replies discuss systems that are also designed to control solar heating gains within the building. Only eighteen percent of systems are designed to remove excess moisture. No documentation was provided on other pollution removal.

C) System Classification

This section is the most important, as it attempts to identify the nature of the ventilation system and the amount of conditioning that is taking place. The whole system is separated into individual tasks in order to achieve a better understanding of the system. How the air is moved into a building or room, the location of its supply and extraction grilles, the heat transfer medium it uses and the levels of supply and conditioning are vital elements in classifying the whole system.

The most common air movement systems are supply and extract (balanced) systems. Fifty three percent of replies discuss buildings having this form of system. A further 30% of buildings also have mechanical supply and extract, but these are pressurised to prevent infiltration. Two percent of replies discuss buildings having extract only systems, while no buildings in this survey have supply only. Balanced systems provide the maximum level of control over the air flow, and also allow the inclusion of heat recovery devices.

The most common location for the air handling plant is a centralised plant (mechanical services) room with 88% of replies discuss buildings having this configuration. Unitary or packaged plant is used only in 18%, while central fresh air with compartmentalised conditioned units are not used in any of the buildings reviewed.

Both all-air and air-water systems appear to be the most common air conditioning systems. Some buildings utilize both configurations, with only 18% of replies mention buildings which incorporate all-water systems. No replies mention buildings with Direct Expansion systems.

Supply and control is almost entirely configured for multizone buildings, with only 18% of replies discussing buildings conditioning single zone spaces. This is perhaps due to the nature

of the building; large commercial office, where perimeter and internal spaces require different amounts of conditioning loads.

With regards to the amount of conditioning of the air, in 82% of replies facilities exist for the air to be either heated or cooled. Humidification or dehumidification is more restricted, with only 18% of described systems having no facilities to condition the air at all.

The most common location for inlet and outlet grilles is in the ceiling, either near the perimeter, internal or distributed. Inlet grilles are also commonly located in external walls while internal walls are common locations for outlet grilles.

D) System Details

This section examines in more detail the classification according to heat transfer medium, classified in section C of the survey, and attempts to separate the system into its individual components. Three types of system have already been identified, all-air systems, air-water systems and all-water systems.

From the replies, Single duct; constant volume; variable temperature; low velocity systems are the most common configurations of all air systems. Fan coils and fan assisted variable air volume are the most common configurations for air water systems. Most systems incorporate a summer-winter changeover facility.

All-water systems are common and include the use of room radiators, either free standing, baseboard, or wall or floor radiators. Ventilation air is supplied separately with these systems, either by natural or mechanical means.

Clearly the above analysis is only based on the seventeen survey replies received and thus any conclusions drawn from such a small number of replies should be examined with great care. Where several replies favour one configuration or application it may not necessarily imply that such systems are most common, only that these systems have been reported upon. For a more statistically accurate survey many more replies are needed.

APPENDIX C2- Ventilation System and Strategy Survey Replies.

BE	Belgium
CA	Canada
DK	Denmark
SF	Finland
F	France
DE	Germany
IT	Italy
NL	Netherlands
NZ	New Zealand
NO	Norway
SE	Sweden
CH	Switzerland
UK	United Kingdom
US	United States of America

(Additional numbers refer to number of replies per country)

(Y - The specified system has the option)

Section B - Design Parameters

Winter:

	DE1	DE2	DE3	SF1	SF2	SF3	NL	IT1	IT2	IT3
Internal Temperature (°C)	20	26	22	21	20	20	21	20	20	20-24
Internal Relative Humidity (%)	45	50	50	-	-	-	-	45	45	45-55
External Temperature (°C)	-15	-12	-12	-27	-26	-26 - - 38	8	-8	-8	-
External Relative Humidity (%)	95	90	90	50	100	-	-	90	90	-

	CH	US1	US2	US3	US4	US5	US6
Internal Temperature (°C)	21-24	22	20	20	21	22	20
Internal Relative Humidity (%)	30	40	40	40	40	-	15
External Temperature (°C)	-8	-6	-30	-15	-17	-10	-40
External Relative Humidity (%)	87	20	20	80	20	-	-

Summer:

	DE1	DE2	DE3	SF1	SF2	SF3	NL	IT1	IT2	IT3
Internal Temperature (°C)	26	28	26	26	25	-	21	-	26	25-28
Internal Relative Humidity (%)	55	50	50	-	50	-	-	-	55	50-55
External Temperature (°C)	32	32	29	26	25	-	35	-	32	-
External Relative Humidity (%)	45	80	80	55	55	-	-	-	50	-

	CH	US1	US2	US3	US4	US5	US6
Internal Temperature (°C)	23-28	28	24	24	24	24	25
Internal Relative Humidity (%)	< 52	40	40	40	40	50	55
External Temperature (°C)	30	31	35	35	35	35	28
External Relative Humidity (%)	37	50	60	50	30	50	38

What is the ventilation system designed for:

- 1 Local dispersion control (e.g. local extraction).
- 2 Displacement ventilation.
- 3 Mixing ventilation.
- 4 Maintenance of a pressure hierarchy (e.g. Difference in pressure prevents mixing of contaminates).

	DE1	DE2	DE3	SF1	SF2	SF3	NL	IT1	IT2	IT3	CH	US1	US2	US3	US4	US5	US6
1			Y				Y	Y					Y	Y	Y		Y
2	Y	Y										Y					
3	Y			Y	Y	Y	Y		Y		Y	Y	Y	Y		Y	Y
4		Y	Y							Y							Y

The Aim of the ventilation system:

- 1 Basic ventilation (Control of pollution due to normal human activities).
- 2 Control of solar heating gains.
- 3 Removal of excess moisture due to washing etc.
- 4 Removal of specific contaminates.
- 5 Removal of combustion products.
- 6 Others.

	DE1	DE2	DE3	SF1	SF2	SF3	NL	IT1	IT2	IT3	CH	US1	US2	US3	US4	US5	US6
1	Y	Y	Y	Y	Y	Y	Y	Y	Y	Y	Y	Y	Y	Y	Y	Y	Y
2		Y	Y	Y		Y	Y										
3		Y											Y	Y			
4							Y			Y					Y		
5																	
6																	

Section C - System Classification.

Classification according to the method of air movement.

- 1 Supply only ventilation (Pressurisation/Full fresh air).
- 2 Extract only ventilation (Depressurisation).
- 3 Supply and Extract - (Balanced).
- 4 Supply and Extract - (Pressurised to prevent infiltration).

	DE1	DE2	DE3	SF1	SF2	SF3	NL	IT1	IT2	IT3	CH	US1	US2	US3	US4	US5	US6
1																	
2								Y						Y	Y		
3	Y	Y		Y	Y	Y					Y		Y			Y	Y
4			Y				Y		Y	Y		Y					

Classification according to the location of air moving equipment.

- 1 Central Station, or centralised plant.
- 2 Unitary or packaged.
- 3 Central fresh air with compartmentalised conditioned units.
- 4 Other.

	DE1	DE2	DE3	SF1	SF2	SF3	NL	IT1	IT2	IT3	CH	US1	US2	US3	US4	US5	US6
1	Y	Y	Y	Y	Y	Y	Y	Y	Y	Y	Y	Y	Y			Y	
2		Y													Y		Y
3																	
4														Y			

Note: US3 - Typically will be a central exhaust system or a single in-line exhaust system.

Classification according to heat transfer medium.

- 1 All air systems.
- 2 Air water systems.
- 3 All water systems.
- 4 Direct expansion systems.

	DE1	DE2	DE3	SF1	SF2	SF3	NL	IT1	IT2	IT3	CH	US1	US2	US3	US4	US5	US6
1	Y	Y	Y				Y			Y			Y		Y	Y	
2	Y	Y		Y	Y		Y				Y	Y					Y
3						Y		Y	Y								
4																	

Classification according to division of supply and control.

- 1 Single Zone.
- 2 Multiple Zone.

	DE1	DE2	DE3	SF1	SF2	SF3	NL	IT1	IT2	IT3	CH	US1	US2	US3	US4	US5	US6
1						Y					Y			Y			
2	Y	Y	Y	Y	Y	Y	Y		Y	Y		Y	Y	Y	Y	Y	Y

Classification according to degree of conditioning.

- 1 None.
- 2 Heat only.
- 3 Cool only.
- 4 Humidify.
- 5 Dehumidify.

	DE1	DE2	DE3	SF1	SF2	SF3	NL	IT1	IT2	IT3	CH	US1	US2	US3	US4	US5	US6
1								Y						Y			
2	Y	Y	Y	Y		Y	Y		Y	Y	Y	Y	Y	Y			Y
3	Y	Y	Y	Y		Y	Y		Y	Y	Y	Y				Y	Y
4	Y	Y	Y				Y		Y	Y	Y		Y	Y		Y	
5	Y	Y	Y				Y		Y	Y				Y			

Classification according to inlet and outlet grilles.

Inlet	DE1	DE2	DE3	SF1	SF2	SF3	NL	IT1	IT2	IT3	CH	US1	US2	US3
Ceiling - Perimeter		Y				Y						Y	Y	
Ceiling - Internal								Y				Y	Y	
Ceiling - Distributed	Y			Y	Y			Y		Y	Y			
Ext. wall - High									Y					Y
Ext. wall - Low														
Int. wall - High		Y			Y	Y							Y	
Int. wall - Low										Y				
Floor - Perimeter						Y								
Floor - Internal		Y												
Floor - Distributed														

Inlet	US4	US5	US6
Ceiling - Perimeter			
Ceiling - Internal	Y		
Ceiling - Distributed		Y	Y
Ext. wall - High			
Ext. wall - Low			
Int. wall - High			
Int. wall - Low			
Floor - Perimeter			
Floor - Internal			
Floor - Distributed			

Outlet	DE1	DE2	DE3	SF1	SF2	SF3	NL	IT1	IT2	IT3	CH	US1	US2	US3
Ceiling - Perimeter		Y					Y	Y						
Ceiling - Internal		Y				Y							Y	Y
Ceiling - Distributed	Y		Y						Y	Y				
Ext. wall - High								Y						Y
Ext. wall - Low														
Int. wall - High				Y	Y	Y			Y		Y	Y*	Y	Y
Int. wall - Low														
Floor - Perimeter												Y		
Floor - Internal		Y				Y								
Floor - Distributed														

Outlet	US4	US5	US6
Ceiling - Perimeter			
Ceiling - Internal		Y	
Ceiling - Distributed			Y
Ext. wall - High			
Ext. wall - Low			
Int. wall - High			
Int. wall - Low			
Floor - Perimeter			
Floor - Internal			
Floor - Distributed			

Section D - System Details.

3 (I)

- 1 Primary air.
- 2 Secondary air.
- 3 Single Duct.
- 4 Dual Duct.
- 5 Constant Volume.
- 6 Variable Volume .
- 7 Intermittently run Fan .
- 8 Continuously run Fan.
- 9 Terminal Reheat .
- 10 Induction .
- 11 High Velocity.
- 12 Low Velocity.
- 13 Constant Temperature.
- 14 Variable Temperature.

	DE1	DE2	DE3	SF1	SF2	SF3	NL	IT1	IT2	IT3	CH	US1	US2	US3	US4	US5	US6
1	Y	Y	Y	Y	Y	Y	Y	Y	Y	Y	Y	Y	Y	Y	Y	Y	Y
2												Y		Y		Y	Y
3	Y	Y	Y	Y						Y	Y				Y		
4							Y						Y				
5	Y	Y	Y	Y	Y	Y		Y	Y	Y						Y	Y
6	Y						Y					Y				Y	
7		Y	Y			Y		Y					Y	Y	Y	Y	Y
8	Y	Y	Y	Y		Y	Y	Y			Y		Y	Y		Y	Y
9		Y	Y	Y							Y						
10	Y																
11			Y													Y	
12	Y	Y		Y		Y			Y	Y			Y	Y		Y	Y
13						Y					Y	Y				Y	Y
14	Y	Y	Y	Y	Y				Y	Y							

3(II)

- 1 Induction.
- 2 Fan Coils.
- 3 Radiant panels.
- 4 Reversible heat pumps.
- 5 Fan assisted VAV.
- 6 Two pipe systems.
- 7 Three pipe systems.
- 8 Four pipe systems.
- 9 Others .

	DE1	DE2	DE3	SF1	SF2	SF3	NL	IT1	IT2	IT3	CH	US1	US2	US3	US4	US5	US6
1																	
2	Y						Y										
3	Y			Y						Y	Y						
4																	Y
5												Y					
6											Y						
7																	
8									Y								
9					Y												

Note: SF2 = Cooling ceiling

- 1 Change over.
- 2 None change over.

	DE1	DE2	DE3	SF1	SF2	SF3	NL	IT1	IT2	IT3	CH	US1	US2	US3	US4	US5	US6
1	Y					Y		Y						Y		Y	Y
2											Y		Y		Y		

3 (III)

All water systems.

- 1 Baseboard Radiation.
- 2 Free standing radiators.
- 3 Wall or floor radiators .
- 4 Bare pipe (Racked on wall).
- 5 Radiant Cooling.
- 6 Other.

	DE1	DE2	DE3	SF1	SF2	SF3	NL	IT1	IT2	IT3	CH	US1	US2	US3	US4	US5	US6
1				Y													
2								Y									
3						Y		Y									
4																	
5		Y															
6																	

THE AIR INFILTRATION AND VENTILATION CENTRE was inaugurated through the International Energy Agency and is funded by the following fourteen countries:

Belgium, Canada, Denmark, Germany, Finland, France, Italy, Netherlands, New Zealand, Norway, Sweden, Switzerland, United Kingdom and United States of America.

The Air Infiltration and Ventilation Centre provides technical support to those engaged in the study and prediction of air leakage and the consequential losses of energy in buildings. The aim is to promote the understanding of the complex air infiltration processes and to advance the effective application of energy saving measures in both the design of new buildings and the improvement of existing building stock.

Air Infiltration and Ventilation Centre

University of Warwick Science Park

Sovereign Court

Sir William Lyons Road

Coventry CV4 7EZ

Great Britain

Tel: +44 (0)203 692050

Fax: +44 (0)203 416306